

DR-150T/E

Service Manual

CONTENTS

● SPECIFICATIONS

- 1) General2
- 2) Transmitter..... 2
- 3) Receiver..... 2

● CIRCUIT DESCRIPTION

- 1) Receiver System..... 3
- 2) Transmitter System..... 3 ~ 4
- 3) PLL Circuit..... 4
- 4) Terminal Function of Microprocessor..... 5 ~ 7
- 5) Terminal Function of 4094..... 8

● SEMICONDUCTOR DATA

- 1) AT24C08-10SI-2.7..... 9
- 2) BU4094BF..... 9
- 3) MB1504LPF-G-BND-TF..... 10
- 4) NJM2902M (T1)..... 10
- 5) NJM7809A..... 11
- 6) RH5VA45AA-T1..... 11
- 7) TA75S01F..... 11
- 8) TA7806F (TE16L)..... 11
- 9) S-AV17..... 12
- 10) TC35305F (TP1)..... 13
- 11) TK10930VTL..... 14
- 12) TC4W66FU..... 15
- 13) μ PC1241H..... 15
- 14) Transistor, Diode and LED Outline Drawings...16
- 15) LCD Connection..... 17

● EXPLODED VIEW

- 1) Bottom View..... 18
- 2) LCD View..... 18
- 3) Top, Front View..... 19

● PARTS LIST

- CPU Unit..... 20 ~ 21
- MAIN Unit..... 22 ~ 25
- VCO Unit..... 26
- SP Unit..... 26
- MIC Unit..... 27
- Mechanical Parts..... 27
- Others..... 28
- Packing..... 28
- Mic. Hanger Unit..... 28
- EJ20u..... 28

● ADJUSTMENT

- 1) Required Test Equipment..... 29
- 2) Adjustment for DR-150T/E..... 30
- 3) Adjustment Points..... 31
- 4) Adjustment Quick Reference..... 31

● VOLTAGE TABLE

- 1) Transistor, FET..... 32
- 2) Diode..... 33
- 3) Connector..... 33
- 4) IC..... 34

● PC BOARD VIEW

- 1) MIC Unit Side A..... 35
- 2) MIC Unit Side B..... 35
- 3) VCO Unit Side A..... 35
- 4) CPU Unit Side A..... 36
- 5) CPU Unit Side B..... 36
- 6) MAIN Unit Side A..... 37
- 7) MAIN Unit Side B..... 38

● BLOCK DIAGRAM

● CIRCUIT DIAGRAM

- 1) MIC Unit..... 40
- 2) VCO Unit..... 41
- 3) Main Unit..... 42
- 4) CPU Unit..... 44
- 5) EJ20u Unit..... 45

ALINCO, INC.

SPECIFICATIONS

1) General

Frequency Coverage:	(DR-150T) TX: 144.000 ~ 147.995MHz (FM) RX: 108.000 ~ 173.995MHz (FM/AM) RX: 440.000 ~ 449.995MHz (FM/AM) (DR-150E) TX: 144.000 ~ 145.995MHz (FM) RX: 144.000 ~ 145.995MHz (FM) RX: 430.000 ~ 439.995MHz (FM)
Modulation:	F2, F3 (FM)
Antenna Impedance:	50Ω unbalanced
Supply Voltage:	13.8 V DC
Current Consumption:	Transmit (High)10.0A / Receive 0.6A
Frequency Stability:	+/-10ppm max.
Dimensions:	140mm(W) x 40mm(H) x 129mm(D)
Weight:	approx. 800g (body only)
Microphone:	(DR-150T) EMS-12 (DTMF mic.) (DR-150E) EMS-5A (plain mic.)

2) Transmitter

Output Power (approx.):	High 50W / Mid 25W / Low 10W
Modulation System:	Reactance Modulation
Spurious Emission:	not more than -60dB
Max. Deviation:	+/-5kHz
Distortion at 60% modulation:	not more than 3%
Microphone Impedance:	2.2kΩ

3) Receiver

Receiving System:	Double Conversion Superheterodyne
Intermediate Frequency:	First: 45.1MHz / Second: 455kHz
Sensitivity (12dB SINAD):	2m band: -16dBμ or better, 70cm band: -10dBμ or better
Selectivity:	-6dB: 12kHz or more, -60dB: 28kHz or less
Squelch Sensitivity:	-20dBμ or better
AF Output:	1.5W
AF Output Impedance:	8Ω

Specifications are subject to change without notice or obligation.

Specifications guaranteed in the amateur band only.

Operating temperature -10°C~+60°C

CIRCUIT DESCRIPTION

1) Receiver System

1. Preamp, Mixer Circuit

The signal from the antenna is passed through a low-pass filter and input to L211. The signal from L211 is led to the base of Q208. The signal from Q208 is led to the triple band pass filter (L212, L213, L214), and gets the high image rejection ratio. The signal from the triple band pass filter is converted into the first IF signal of 45.1MHz. The receiving signal is led to the gate 1 of Q209, and the first local oscillator signal is led to the gate 2 of Q209. To reduce the high adjacent channel interference, the band width of the X203 is set to 20kHz. The signal from X203 is amplified by Q214, and input to FM IF system IC201 of TK10930.

2. IF and AF Circuit

The TK10930 has the second local oscillator circuit, mixer circuit, detector circuit, squelch circuit, and so on. Pin1 and 2 are the terminals of the crystal oscillator circuit. Pin3 of IC201 is connected to CFW201 directly because the matching resistor for ceramic filter is built-in. The quadrature circuit (pin11 of IC201) is connected to the L221. The signal from pin12 of IC201 is connected to the LPF. The detected AF signal, which has flat frequency characteristics, is led to the control unit and used as both squelch signal and tone squelch signal. De-emphasis circuit consists of R257, R258, C282 and C284. The amplifier consisting of Q215 and Q217 is located far away from the VR in the control unit, so it outputs the high voltage signal to prevent S/N from the deterioration. The squelch switch circuit consists of Q216 and Q235, and switches on/off at the point where there is no voltage to prevent from the switching noise. The S meter signal from pin16 of IC201 is led to the CPU in the control unit after adjusting the level at VR206. The noise amplifier consists of pin19 and 20, the built-in OP amplifier in IC201. The output signal of noise amplifier is amplified by Q218, rectified by D216, and then led to the pin21 (hysteresis comparator input) of IC201. IC202 is about 5W audio power amplifier IC.

2) Transmitter System

1. Modulation Circuit

The microphone amplifier IC501(IDC, LPF) consists of four operational amplifiers. The signal from the microphone is led to amplifier circuit consisting of IC501C and then input to the pre-emphasis circuit consisting of C503. And then input to the limiter circuit IC501B. The limiter circuit uses the saturation of the OP amplifier. The amplified signal is input to the low-pass filter IC501A. The output signal is led to amplifier circuit consisting of IC502, and the signal is passed through variable resistor VR204 for modulation adjustment and input to the VCO unit. Sub tone signal is input to the low-pass filter IC501D. Sub tone deviation is determined by VR205.

2. TX Amp. Circuit

The signal from VCO is amplified by TX, RX wide band LO amplifier Q207. The signal from Q207 is passed through the transmission/reception selector, and amplified by Q206 and Q202. The PA unit is driven at 200mW driving power.

3. PA Circuit

IC208 is 50W powered amplifier module. The output power is controlled by the voltage of Pin3. The RF signal amplified 50W in PA is passed through D201 and low-pass filter, and input to the antenna connector.

4. ALC Circuit

The power detection circuit consisting of D204 rectifies the output signal voltage. VR201 is middle power adjust trimmer pot. VR202 is high power adjust trimmer pot. The detected DC voltage is amplified by Q203, Q204 and Q205. Output power is controlled by voltage of Pin3 in IC5 and collector voltage of Q202. When the temperature goes up unusually, the power down circuit consisting of Q238, R316 and TH202 works to prevent the device from the destruction.

3) PLL Circuit

The VHF-VCO circuit consisting of Q402, Q404, D404, D405, and D406. The transmission/reception shift circuit consisting of Q404. The UHF-VCO circuit consisting of Q401, D401, D402, and D403. IC205 is pulse swallow system based PLL IC with the built-in prescaler, which synthesizes 145MHz-band and 435MHz signal. The loop filter consisting of R242, R243, R319, R320, C258, C350 and C352.

4) Terminal Function of Microprocessor

No.	Name	Pin Name	I/O	Logic	Description
01	AVcc	AVCC		-	A/D Power supply
02	AN0	BP1	I	A/D	Band plan1 (USA, General, EU A, EU B)
03	AN1	BP2	I	A/D	Band plan 2 (RX, TX expansion)
04	AN2	SMT	I	A/D	S meter voltage input
05	AN2	XWR	I	-	Command request, IF frequency switch
06	AVss	AVss		-	A/D GND
07	TEST			-	Connected to Vcc
08	OSC1	OSC1	I	-	4MHz OSC1
09	OSC2	OSC2	O	-	4MHz OSC2
10	RESET	RESET	I	Active High	CPU Reset
11	X1		I	-	Connected to Vcc
12	X2		O	-	Open
13	GND	GND		-	CPU GND
14	D0	SDA	I/O	PULSE	EEPROM data (built-in, option ROM)
15	D1	SCL1	O	PULSE	EEPROM clock1
16	D2	SCL2	O	PULSE	EEPROM clock2 (option board)
17	D3	RMS	I	Active Low	Microphone remote control input
18	D4	UP	I	Active Low	Microphone up input
19	D5	DN	I	Active Low	Microphone down input
20	D6	LMP	O	Active High	Dimmer
21	D7	UNLK	I	Active High	PLL unlock signal input
22	D8	STB2	O	Active High	CTCSS strobe
23	D9	TDO	I	Active Low	CTCSS tone detection input
24	D10/STOPC	TID	I	Active Low	CTCSS unit detection input
25	D11/INT0	BUP	I	Active Low	Back up signal detection input
26	R00/INT1	SQD	I	Active Low	Squelch input
27	R01/INT2	ENC1	I	Active Low	Rotary encoder up input
28	R02/INT3	ENC2	I	Active Low	Rotary encoder down input
29	R03/INT4	DV	I	Active High	DTMF signal detection input
30	R10/TOB	BEEP	O	PULSE	Beep tone output
31	R11/TOC	TB	O	PULSE	Tone burst (1750Hz) output (TX)
		RX BUSY	O	Active High	Busy: Low out put (RX)
32	R12/TOD	TXLMP	O	Active High	TX: High
33	R13/EVNB	MSW	O	Active High	Microphone mute output

No.	Name	Pin Name	I/O	Logic	Description
34	R20/EVND	TONE1	O	-	Subtone output1
35	R21/SCK	TONE2	O	-	Subtone output2
36	R22/SI	TONE3	O	-	Subtone output3
37	R23/SO	TONE4	O	-	Subtone output4
38	R30/SEG1	DT1	I	Active High	DTMF data1
39	R31/SEG2	DT2	I	Active High	DTMF data2
40	R32/SEG3	DT3	I	Active High	DTMF data3
41	R33/SEG4	DT4	I	Active High	DTMF data4
42	R40/SEG5	CLK	O	Active High	Clock (CTCSS,PLL, 4094)
43	R41/SEG6	DATA	O	Active High	Data (CTCSS,PLL, 4094)
44	R42/SEG7	STBP	O	Active High	PLL Strobe
45	R43/SEG8	STBS	O	Active High	4094 Strobe
46	R50/SEG9	PTT	I	Active Low	PTT input
47	R51/SEG10	KR1	O	-	Key matrix output1
48	R52/SEG11	KR2	O	-	Key matrix output2
49	R53/SEG12	KR3	O	-	Key matrix output3
50	R60/SEG13	KC1	I	-	Key matrix input1
51	R61/SEG14	KC2	I	-	Key matrix input2
52	R62/SEG15	KC3	I	-	Key matrix input3
53	R63/SEG16	KC4	I	-	Key matrix input4
54	R70/SEG17	SEG0	O	-	LCD SEG0
55	R71/SEG18	SEG1	O	-	LCD SEG1
56	R72/SEG19	SEG2	O	-	LCD SEG2
57	R73/SEG20	SEG3	O	-	LCD SEG3
58	SEG21	SEG4	O	-	LCD SEG4
59	SEG22	SEG5	O	-	LCD SEG5
60	SEG23	SEG6	O	-	LCD SEG6
61	SEG24	SEG7	O	-	LCD SEG7
62	SEG25	SEG8	O	-	LCD SEG8
63	SEG26	SEG9	O	-	LCD SEG9
64	SEG27	SEG10	O	-	LCD SEG10
65	SEG28	SEG11	O	-	LCD SEG11
66	SEG29	SEG12	O	-	LCD SEG12
67	SEG30	SEG13	O	-	LCD SEG13
68	SEG31	SEG14	O	-	LCD SEG14

No.	Name	Pin Name	I/O	Logic	Description
69	SEG32	SEG15	O	-	LCD SEG15
70	SEG33	SEG16	O	-	LCD SEG16
71	SEG34	SEG17	O	-	LCD SEG17
72	SEG35	SEG18	O	-	LCD SEG18
73	SEG36	SEG19	O	-	LCD SEG19
74	SEG37	SEG20	O	-	LCD SEG20
75	SEG38	SEG21	O	-	LCD SEG21
76	SEG39	SEG22	O	-	LCD SEG22
77	SEG40	SEG23	O	-	LCD SEG23
78	SEG41	SEG24	O	-	LCD SEG24
79	SEG42	SEG25	O	-	LCD SEG25
80	SEG43	SEG26	O	-	LCD SEG26
81	SEG44	SEG27	O	-	LCD SEG27
82	SEG45	SEG28	O	-	LCD SEG28
83	SEG46	SEG29	O	-	LCD SEG29
84	SEG47	SEG30	O	-	LCD SEG30
85	SEG48	SEG31	O	-	LCD SEG31
86	SEG49	SEG32	O	-	LCD SEG32
87	SEG50	SEG33	O	-	LCD SEG33
88	SEG51	SEG34	O	-	LCD SEG34
89	SEG52	SEG35	O	-	LCD SEG35
90	COM1	COM1	O	-	LCD SEG36
91	COM2	COM2	O	-	LCD SEG37
92	COM3	COM3	O	-	LCD SEG38
93	COM4		O	-	LCD SEG39
94	V1	LV1		-	LCD Power supply
95	V2	LV2		-	LCD Power supply
96	V3	LV3		-	LCD Power supply
97	Vcc	VCC		-	CPU Power supply
98	TONEC	DTC	O	-	DTMF tone C output
99	TONER	DTR	O	-	DTMF tone R output
100	VTref	VTR	I	-	DTMF output reference level power supply

5) Terminal Function of 4094

No.	Pin Name	Function	I/O	Logic	Description
P1-1	RFM	RF power mid control	O	Active Low	L=Power Mid
P1-2	RFL	RF power low control	O	Active Low	L=Power Low
P1-3	-	-	-	-	-
P1-4	R145	RX 145 power control	O	Active Low	L=RX 145 power ON
P1-5	R360	RX 360 power control	O	Active Low	L=RX 360 power ON
P1-6	R440	RX 440 power control	O	Active Low	L=RX 440 power ON
P1-7	R870	RX 870 power control	O	Active Low	L=RX 870 power ON
P1-8	SIFT	RX SIFT control	O	Active Low	L=SHIFT ON
P2-1	-	-	-	-	-
P2-2	AFMUTE	AF mute control	O	Active High	H=AF mute ON
P2-3	AM/FM	AM/FM control	O	Active Low	L=AM
P2-4	LIZH	LIZH control	O	Active High	H=LIZH ON
P2-5	VCO1	VCO1 power control	O	Active Low	L=VCO1 power ON
P2-6	VCO2	VCO2 power control	O	Active Low	L=VCO2 power ON
P2-7	RFATT	RFATT control	O	Active Low	L=RF ATT ON
P2-8	-	-	-	-	-

SEMICONDUCTOR DATA

1) AT24C08-10SI-2.7 (XA0367) EEPROM 1024 x 8Bit

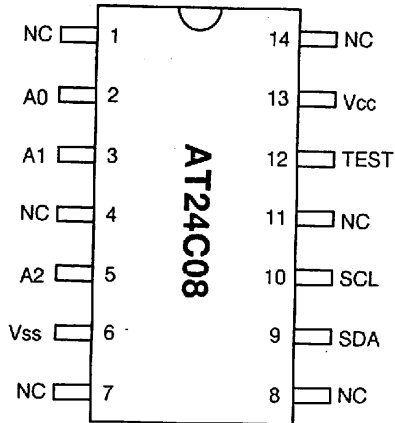

Pin Names

A0 ~ A2	Address inputs
SDA	Serial Data
SCL	Serial Clock
TEST	Hold at Vss
Vss	Ground
Vcc	+5V

2) BU4094BF (XA0246) 8-Stage Shift Register

Function Table

Clock	Output enable	Strobe	Data	Parallel outputs		Serial outputs	
				Q1	Qn	Qs	Q's
	L	X	X	Z	Z	Q7	No Chg.
	L	X	X	Z	Z	No Chg.	Qs
	H	L	X	No Chg.	No Chg.	Q7	No Chg.
	H	H	L	L	Qn-1	Q7	No Chg.
	H	H	H	H	Qn-1	Q7	No Chg.
	H	X	X	No Chg.	No Chg.	No Chg.	Qs

Z=High Impedance
X=Don't Care

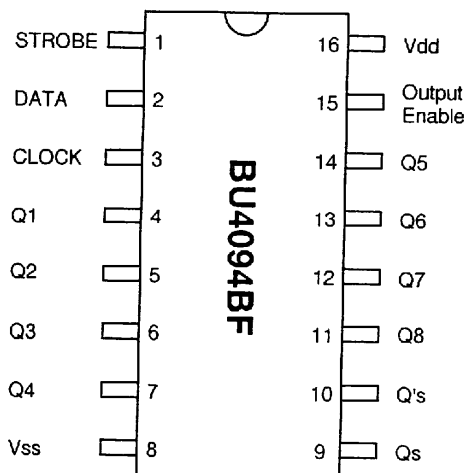

Block Diagram

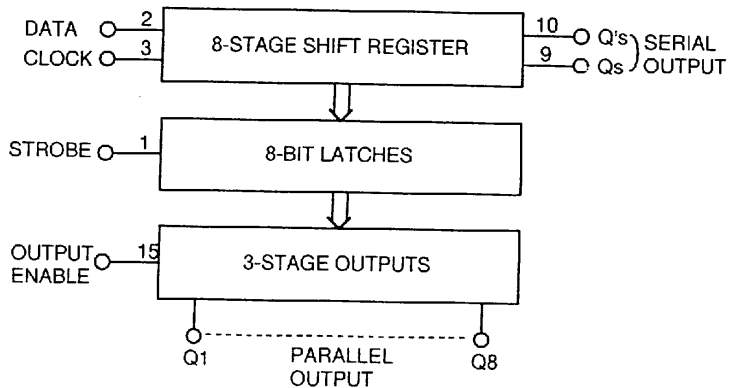

3) MB1504LPF-G-BND-TF (XA0145) Frequency Synthesizer

Function Table

FC input	P.D.input	Do output
High or Low	$f_r = f_p$	Hi Z
High	$f_r > f_p$	High
High	$f_r < f_p$	Low
Low	$f_r > f_p$	Low
Low	$f_r < f_p$	High

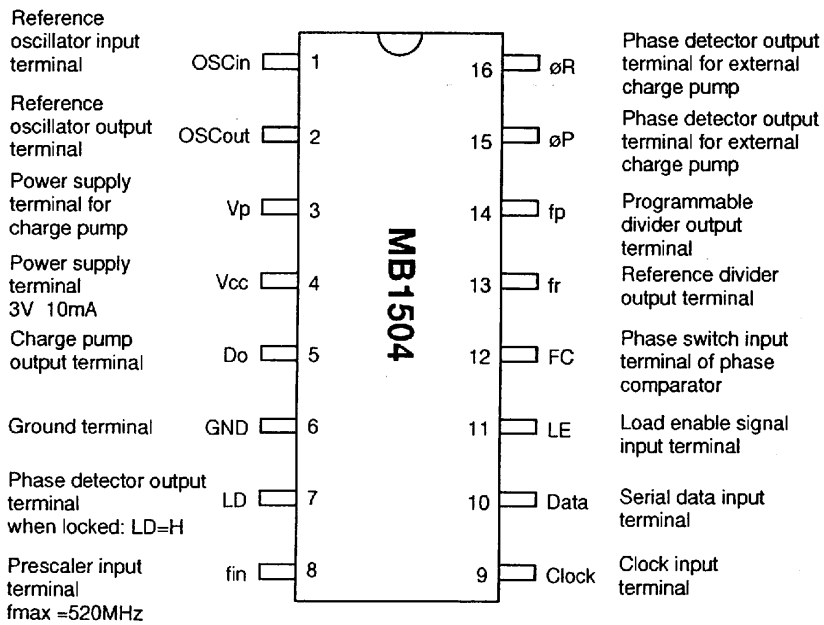

4) NJM2902M (T1) (XA0265) Operational Amplifiers

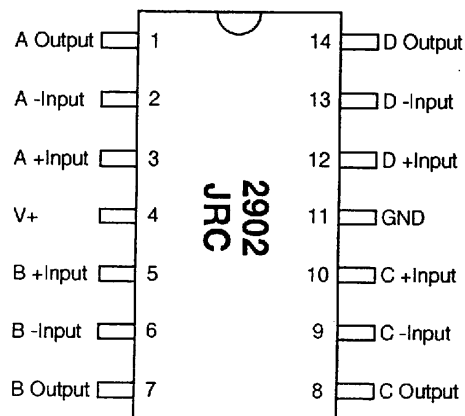

5) NJM7809A (XA0264)
9V 2.2A Voltage Regulator

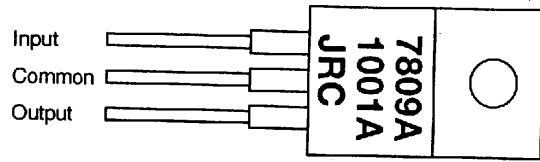

6) RH5VA45AA-T1 (XA0208)
C-MOS Voltage Detector

Equivalent Circuit

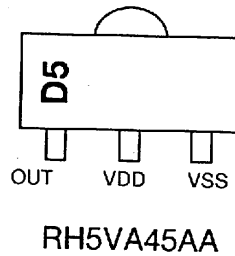
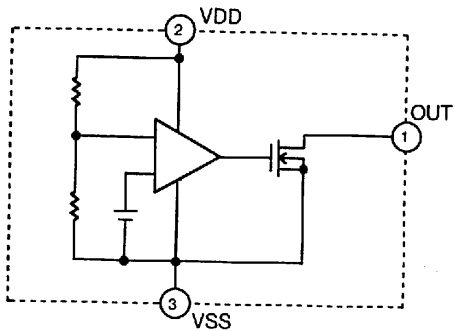

7) TA75S01F (XA0328)
Single Operational Amplifiers

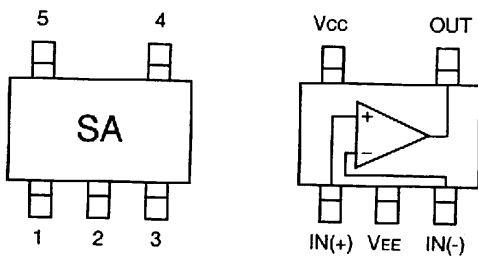

8) TA7806F (TE16L) (XA0267)
6V 1A Voltage Regulator

Test Circuit

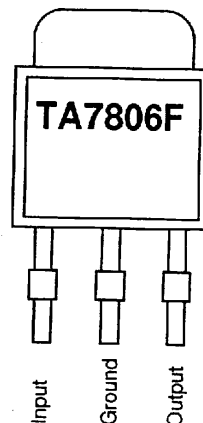
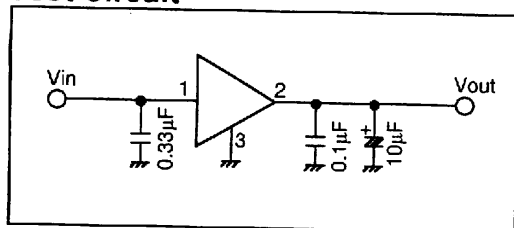

9) S-AV17 (XA0185)
 144 ~ 148MHz 60W
 RF Power Module

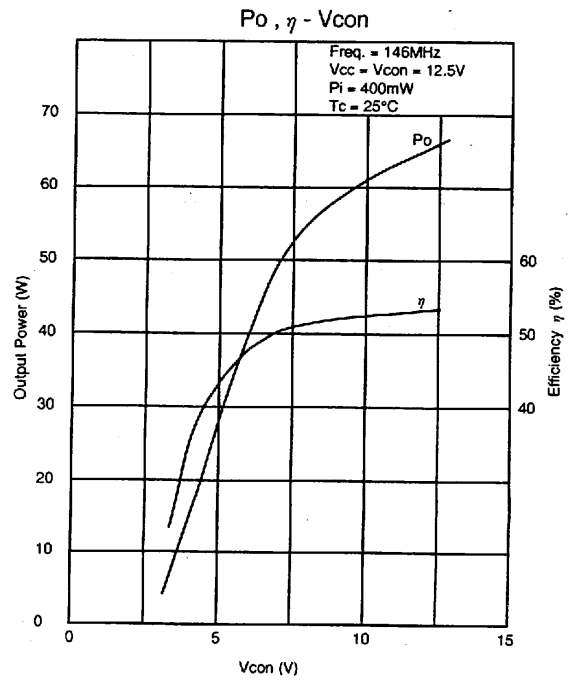
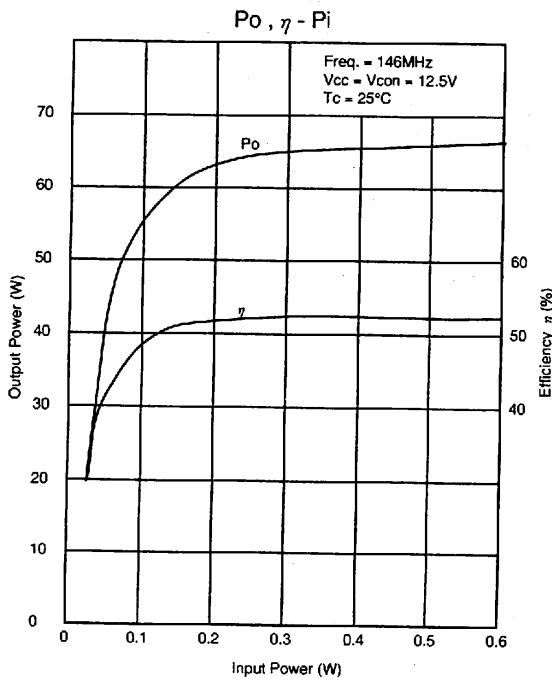
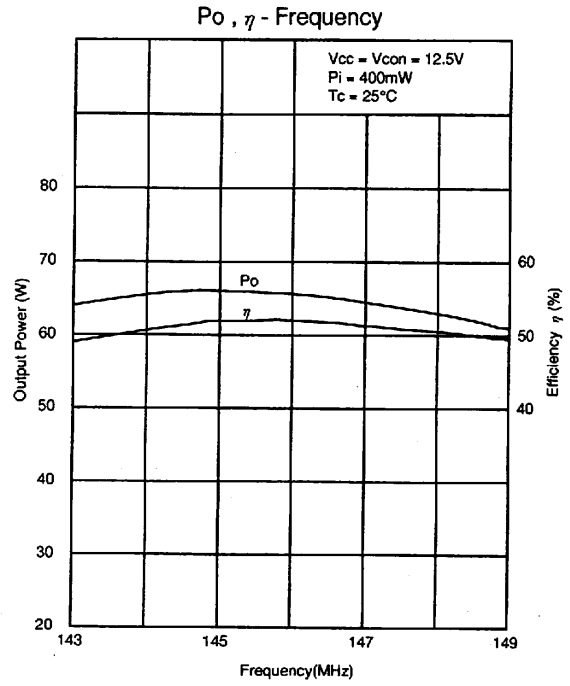
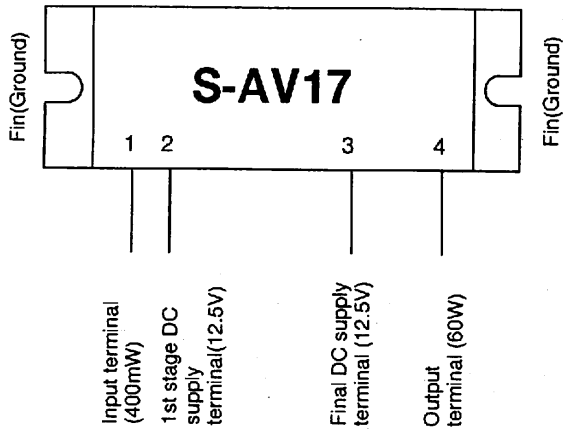

10) TC35305F (TP1) (XA0268) DTMF Receiver

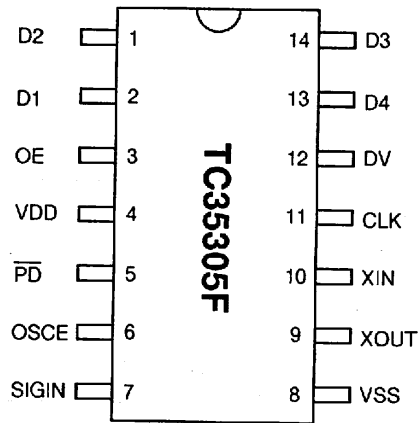

Function Table

FL	FH	Digit	OE	D4	D3	D2	D1
697	1209	1	H	L	L	L	H
697	1336	2	H	L	L	H	L
697	1477	3	H	L	L	H	H
770	1209	4	H	L	H	L	L
770	1336	5	H	L	H	L	H
770	1477	6	H	L	H	H	L
852	1209	7	H	L	H	H	H
852	1336	8	H	H	L	L	L
852	1477	9	H	H	L	L	H
941	1336	0	H	H	L	H	L
941	1209	*	H	H	L	H	H
941	1477	#	H	H	H	L	L
697	1633	A	H	H	H	L	H
770	1633	B	H	H	H	H	L
852	1633	C	H	H	H	H	H
941	1633	D	H	L	L	L	L
-	-	ANY	L	Z	Z	Z	Z

No.	Name	I/O	Description
2	D1	O	OE="L"; Hi impedance, "H"; data is output
1	D2	O	OE="L"; Hi impedance, "H"; data is output
14	D3	O	OE="L"; Hi impedance, "H"; data is output
13	D4	O	OE="L"; Hi impedance, "H"; data is output
3	OE	I	When OE is "High", D1~D4 are enable.
4	VDD	V	Power Supply; 5V
5	PD	I	PD="Low"; stand by mode
6	OSCE	I	Control terminal of the oscillator stage
7	SIGIN	I	Signal input terminal
8	VSS	G	0V
9	XOUT	O	Crystal terminal (3.579545MHz)
10	XIN	I	Crystal terminal (3.579545MHz)
11	CLK	I/O	"H"; external clock output "L"; external clock input
12	DV	O	Data valid

Block Diagram

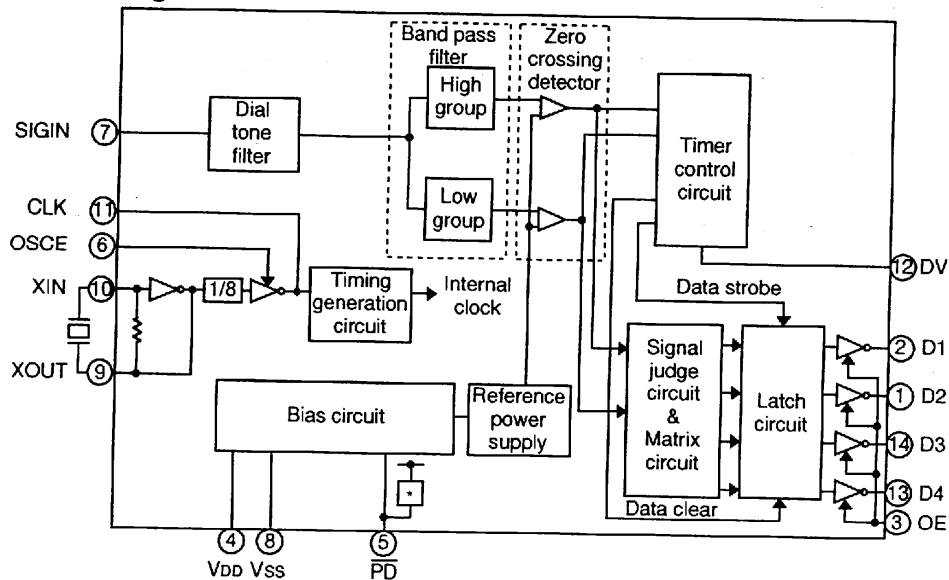

11) TK10930VTL (XA0223) Narrow Band FM IF IC

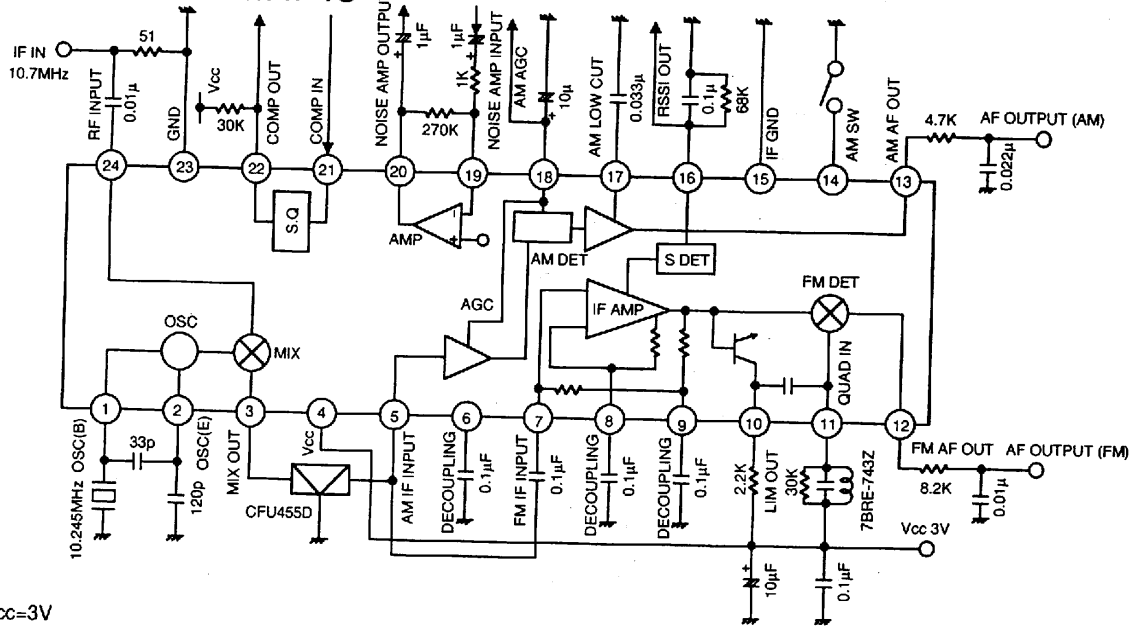

Vcc=3V

Characteristic	Symbol	Min.	Typical	Max	Typical	Condition
Supply Current 1	Icc1		6.8	8.9	mA	No signal, AM ON
Supply Current 2	Icc2		3.9	5.3	mA	No signal, AM OFF
Mixer Conversion Gain	Mg		20		dB	
Mixer Input Impedance	Mz		3.6		KΩ	DC Test
FM						
Limiting Sensitivity	Limit		2.0	8.0	µV	-3.0dB
Output Voltage	Vo1	85	150	230	mVrms	10mVin +/-3kHz DEV
Distortion	THD1		1.0	2.0	%	10mVin +/-3kHz DEV
Output Impedance	Zo		800		Ω	10mVin
Filter Gain	Gf	30	38		dB	Fin=30kHz, Vo=100mV
Scan Control Hi Voltage	SH	2.3			V	Squelch input=2.5V
Scan Control Low Voltage	SL			0.3	V	Squelch input=0V
Squelch Hysteresis	Hys		30		mV	
S meter Output Voltage	S0		0.05	0.5	V	Vin=0mV, RS=68kΩ
S meter Output Voltage	S1	0.05	0.5	0.9	V	Vin=0.01mV, RS=68kΩ
S meter Output Voltage	S2	0.7	1.2	1.7	V	Vin=0.1mV, RS=68kΩ
S meter Output Voltage	S3	1.2	1.8	2.5	V	Vin=1mV, RS=68kΩ
S meter Output Voltage	S4	1.6	2.3	2.9	V	Vin=10mV, RS=68kΩ
S meter Output Voltage	S5	1.8	2.4	2.9	V	Vin=100mV, RS=68kΩ
AM						
Sensitivity	US	20	15		µV	When output is 20mVrms.
Output Voltage	Vo2	60	120	160	mVrms	1kHz, 30%, Vin=1mV
Distortion-1	THD2		1.0	2.0	%	1kHz, 30%, Vin=1mV
Distortion-2	THD3		2.0	4.0	%	1kHz, 30%, Vin=1mV
S/N	Vo1	40	48		dB	1kHz, 30%, Vin=1mV
AM OFF	Vo	-0.3		0.3	%	OFF

12) TC4W66FU (TE12L) (XA0306)
Dual Bilateral Switch

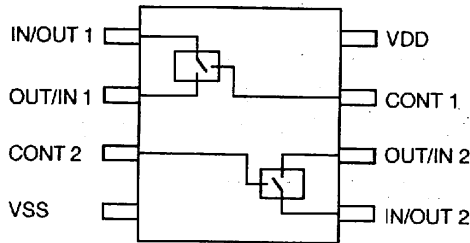
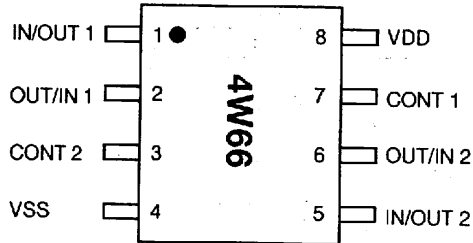

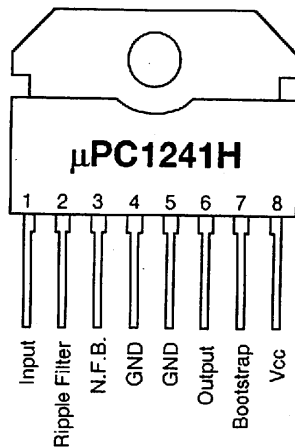
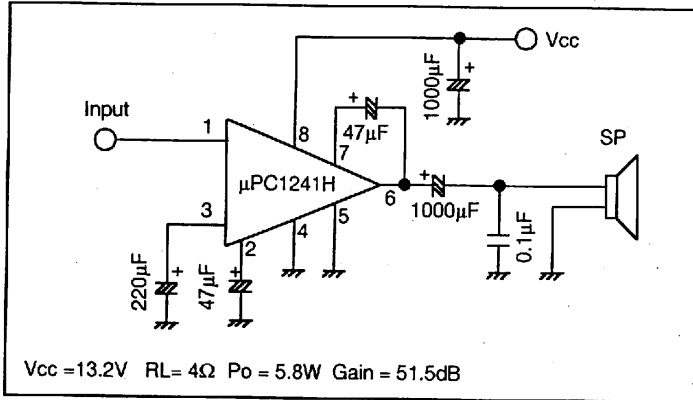

13) μ PC1241H (XA0079)
Audio Power Amplifiers

Test Circuit

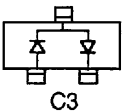
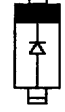

14) Transistor, Diode and LED Outline Drawings

Top View

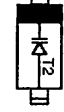
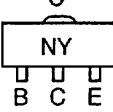
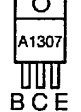
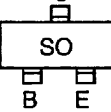
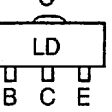
1SS226 XD0103	1SS356 XD0272	1SV214 XD0131	1SV215 XD0132	2SA1213Y XT0088	2SA1307Y XT0092	2SA1586GR XT0120	2SA1736 XT0099
							
2SC2873Y YT0113	2SC2954 YT0084	2SC3356 YT0110	2SC3585 YT0100	2SC4116GR YT0102	2SC4213A YT0105	2SC4215Y YT0104	2SC4226 YT0141

15) LCD Connection (EL0025)

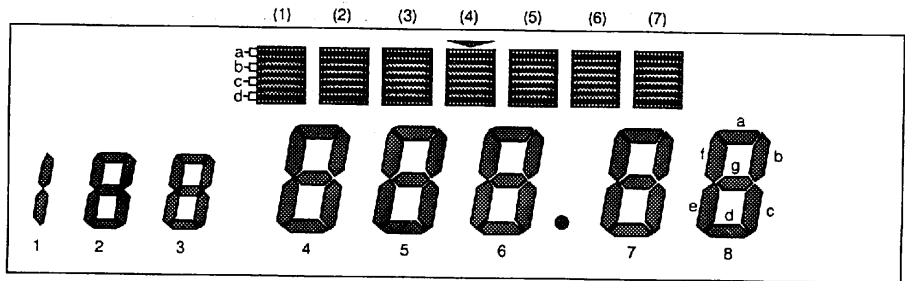
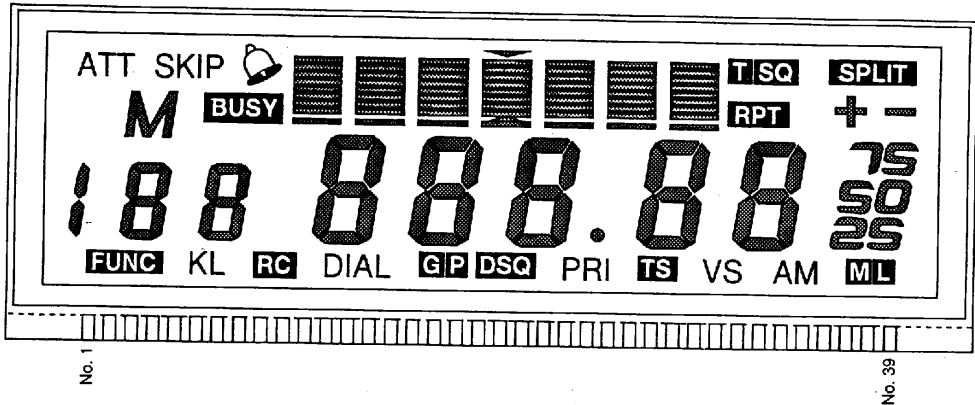

Pin No.	Signal Name	Pin No. 90 COM1	Pin No. 91 COM2	Pin No. 92 COM3	Pin No.	Signal Name	Pin No. 90 COM1	Pin No. 91 COM2	Pin No. 92 COM3
1	0		(3)b	(3)a	21	20	●	6c	6b
2	1	SKIP	(2)b	(2)a	22	21	TS	7e	7f
3	2	ATT	(1)b	(1)a	23	22	7d	7g	7a
4	3	BUSY	(1)c	(1)d	24	23	VS	7c	7b
5	4		(2)c	(2)d	25	24	AM	8e	8f
6	5		(3)c	(3)d	26	25	8d	8g	8a
7	6	FUNC	2e	2f	27	26	M	8c	8b
8	7	2d	2g	2a	28	27	L	25	50
9	8	1b.c	2c	2b	29		COM.1		
10	9	KL	3e	3f	30			COM.2	
11	10	3d	3g	3a	31				COM.3
12	11	RC	3c	3b	32	28	75	(4)c	(4)d
13	12	DIAL	4e	4f	33	29	-	(5)c	(5)d
14	13	4d	4g	4a	34	30	+	(6)c	(6)d
15	14	G	4c	4b	35	31	RPT	(7)c	(7)d
16	15	P	5e	5f	36	32	T	(7)b	(7)a
17	16	5d	5g	5a	37	33	SQ	(6)b	(6)a
18	17	DSQ	5c	5b	38	34	SPLIT	(5)b	(5)a
19	18	PRI	6e	6f	39	35	▼	(4)b	(4)a
20	19	6d	6g	6a					

EXPLODED VIEW

1) Bottom View

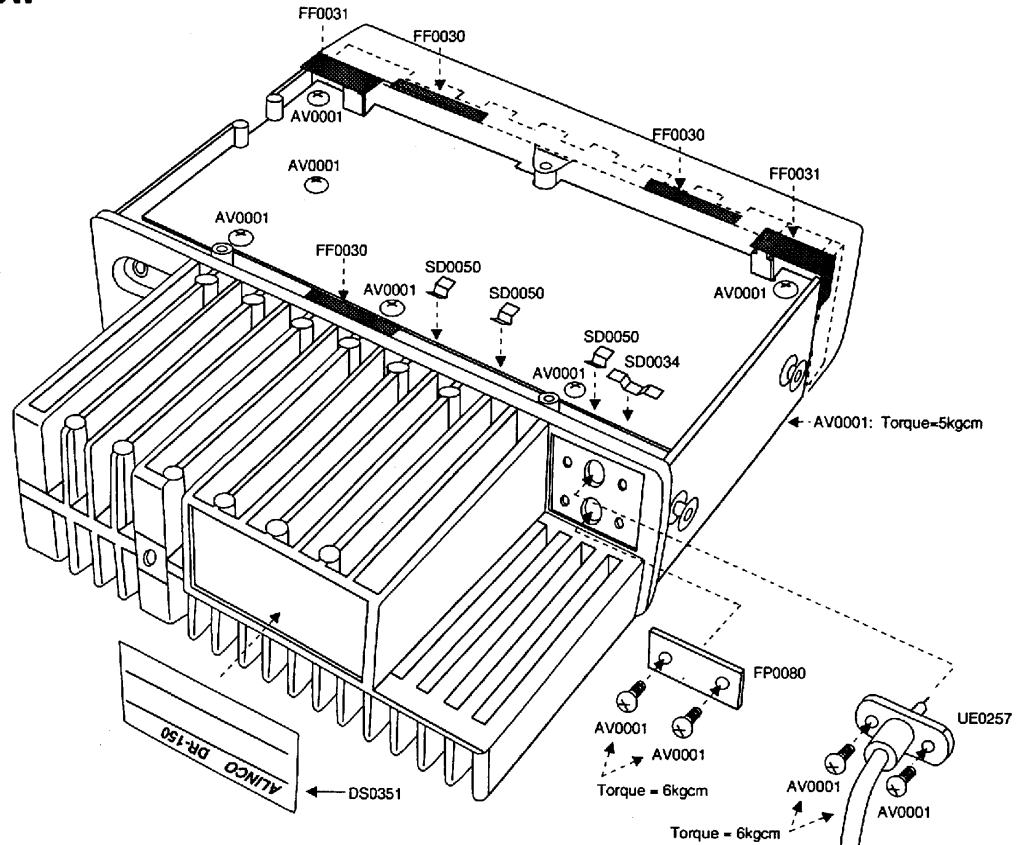

2) LCD View

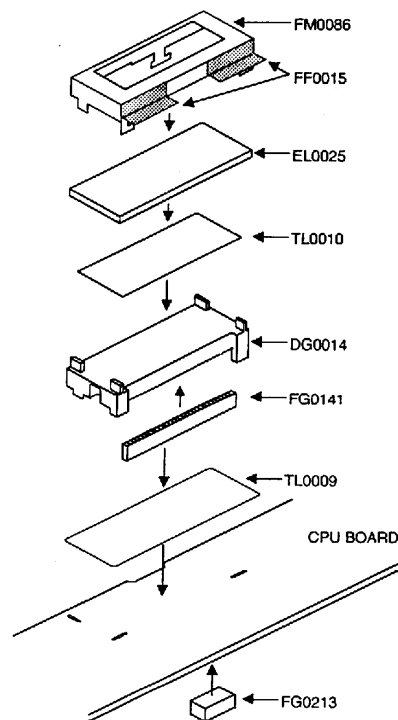

3) Top, Front View

AD0010, AE0014, AK0003: Torque=5kgcm

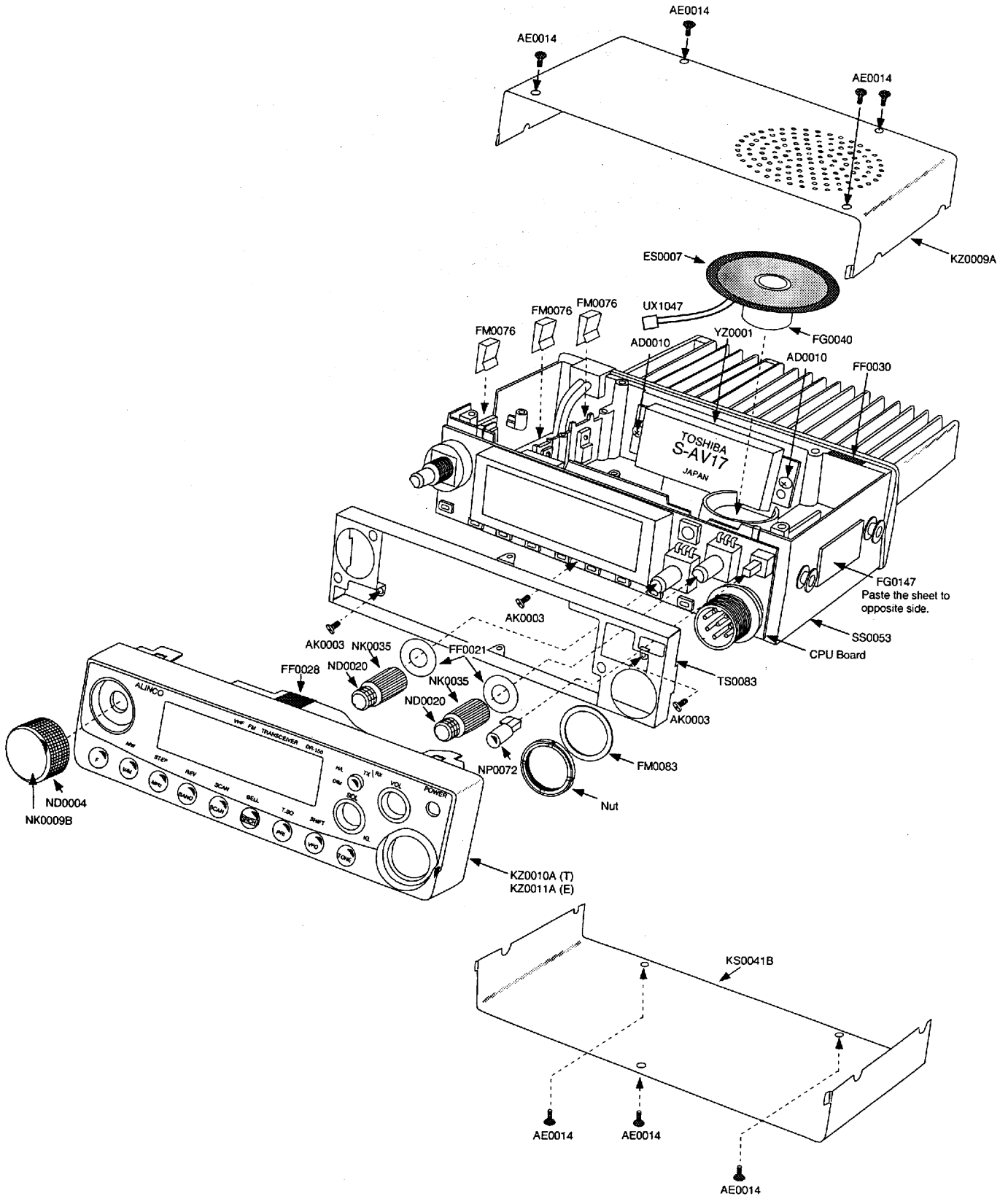

PARTS LIST

CPU Unit

Ref. No.	Parts No.	Description	Parts Name	Ver.	Ref. No.	Parts No.	Description	Parts Name	Ver.
CPU Unit									
C101	CU3035	Chip C.	C1608JB1H102KT-A		D101	XD0187	Diode	DTZ11B(TT11)	
C102	CU3059	Chip C.	C1608JF1E104ZT-A		D102	XD0231	Diode	DAP202U(T106)	
C103	CU3059	Chip C.	C1608JF1E104ZT-A		D103	XD0231	Diode	DAP202U(T106)	
C104	CU3047	Chip C.	C1608JB1H103KT-A		D106	XD0231	Diode	DAP202U(T106)	
C105	CU3059	Chip C.	C1608JF1E104ZT-A		D108	XD0230	Diode	DAN202U(T106)	
C106	CU3059	Chip C.	C1608JF1E104ZT-A		D109	XD0230	Diode	DAN202U(T106)	
C107	CU3047	Chip C.	C1608JB1H103KT-A		IC101	XA0371	IC	HD404629H_T/E	
C108	CU3035	Chip C.	C1608JB1H102KT-A		IC102	XA0268	IC	TC35305F(TP1)	
C109	CU3035	Chip C.	C1608JB1H102KT-A		IC103	XA0208	IC	RH5VA45AA-T1	
C110	CU3035	Chip C.	C1608JB1H102KT-A		IC104	XA0328	IC	AT24C08-10SI-2.7	
C111	CU3035	Chip C.	C1608JB1H102KT-A		IC105	XA0306	IC	TC4W66FU(TE12L)	
C112	CU3035	Chip C.	C1608JB1H102KT-A		J101	UE0192	Connector	11R-JE	
C114	CU3035	Chip C.	C1608JB1H102KT-A		J102	UE0192	Connector	11R-JE	
C115	CU3035	Chip C.	C1608JB1H102KT-A		J103	UE0170	Connector	B9B-ZR	
C116	CU3023	Chip C.	C1608CH1H101JT-A		J104	UE0194	Connector	FM214-8SMPYNW	
C120	CU3035	Chip C.	C1608JB1H102KT-A		L101	QC0334	Coil	NL453232T-271J	
C121	CU3023	Chip C.	C1608CH1H101JT-A		LC101	EL0025	LCD	HLC8413-012301	
C122	CU3023	Chip C.	C1608CH1H101JT-A		LC102	FM0086		LCD Holder	
C123	CU3035	Chip C.	C1608JB1H102KT-A		LC103	DG0014		LCD Light	
C124	CU3023	Chip C.	C1608CH1H101JT-A		LC104	FG0141		LCD Connector	
C125	CU3035	Chip C.	C1608JB1H102KT-A		LC105	TL0009		LCD Filter	
C126	CU3035	Chip C.	C1608JB1H102KT-A		LC106	TL0010		LCD Filter	
C127	CU3023	Chip C.	C1608CH1H101JT-A		LD101	XL0032	LED	CL-170YG-CD-T	
C128	CU3035	Chip C.	C1608JB1H102KT-A		LD102	XL0032	LED	CL-170YG-CD-T	
C129	CU3035	Chip C.	C1608JB1H102KT-A		LD103	XL0032	LED	CL-170YG-CD-T	
C130	CU3035	Chip C.	C1608JB1H102KT-A		LD104	XL0032	LED	CL-170YG-CD-T	
C131	CU3035	Chip C.	C1608JB1H102KT-A		LD105	XL0032	LED	CL-170YG-CD-T	
C132	CU3047	Chip C.	C1608JB1H103KT-A		LD106	XL0032	LED	CL-170YG-CD-T	
C133	CU3047	Chip C.	C1608JB1H103KT-A		LD107	XL0032	LED	CL-170YG-CD-T	
C134	CU3035	Chip C.	C1608JB1H102KT-A		LD108	XL0032	LED	CL-170YG-CD-T	
C135	CU3023	Chip C.	C1608CH1H101JT-A		LD109	XL0038	LED	CL-200YG-C-TS	
C136	CU3023	Chip C.	C1608CH1H101JT-A		LD110	XL0038	LED	CL-200YG-C-TS	
C137	CU3035	Chip C.	C1608JB1H102KT-A		LD111	XL0038	LED	CL-200YG-C-TS	
C138	CU3035	Chip C.	C1608JB1H102KT-A		LD112	XL0038	LED	CL-200YG-C-TS	
C139	CS0220	Chip Tantal	TMCMA1C225MTR		LD113	XL0038	LED	CL-200YG-C-TS	
C140	CU3023	Chip C.	C1608CH1H101JT-A		LD114	XL0038	LED	CL-200YG-C-TS	
C141	CU3059	Chip C.	C1608JF1E104ZT-A		LD115	XL0032	LED	CL-170YG-CD-T	
C142	CU3023	Chip C.	C1608CH1H101JT-A		LD116	XL0032	LED	CL-170YG-CD-T	
C145	CU3023	Chip C.	C1608CH1H101JT-A		LD117	XL0032	LED	CL-170YG-CD-T	
C146	CS0220	Chip Tantal	TMCMA1C225MTR		LD118	XL0032	LED	CL-170YG-CD-T	
C147	CU3023	Chip C.	C1608CH1H101JT-A		LJ101	MRCLH8GG	Lead	_#30RH1-085-H1	
C148	CU3059	Chip C.	C1608JF1E104ZT-A		LJ103	MACLH8GG	Lead	_#30AH1-085-H1	
C150	CU3047	Chip C.	C1608JB1H103KT-A		LS101	UQ0014		LS22BB-2SD/PG-T	
C151	CU3031	Chip C.	C1608JB1H471KT-A		M1101	FP0034		Mic. Spacer	
C152	CS0220	Chip Tantal	TMCMA1C225MTR		PC101	UP0258A	P.C.B		
C153	CU3017	Chip C.	C1608CH1H330JT-A						
C154	CU3017	Chip C.	C1608CH1H330JT-A						
C155	CU3059	Chip C.	C1608JF1E104ZT-A						
C156	CS0220	Chip Tantal	TMCMA1C225MTR						
C157	CS0220	Chip Tantal	TMCMA1C225MTR						
C158	CU3059	Chip C.	C1608JF1E104ZT-A						

Ref. No.	Parts No.	Description	Parts Name	Ver.	Ref. No.	Parts No.	Description	Parts Name	Ver.
Q101	XT0113	Transistor	2SC2873YTE12L		R142	RK3050	Chip. R	ERJ3GSYJ103V	
Q102	XU0029	Transistor	DTC114YUT106		R143	RK3040	Chip. R	ERJ3GSYJ152V	
Q103	XU0088	Transistor	2SA1213Y(TE12L)		R144	RK4063	Chip. R	ERJ14YJ181H	
Q104	XU0042	Transistor	FMC1(T98)		R145	RK1020	Chip. R	ERJ8GEYJ151V	
Q105	XU0112	Transistor	DTA114YUT106		R146	RK3054	Chip. R	ERJ3GSYJ223V	
Q106	XU0029	Transistor	DTC114YUT106		R147	RK3050	Chip. R	ERJ3GSYJ103V	
Q107	XU0152	Transistor	UMC5(TR)		R149	RK3028	Chip. R	ERJ3GSYJ151V	
Q108	XU0029	Transistor	DTC114YUT106		R150	RK3060	Chip. R	ERJ3GSYJ683V	E
Q109	XU0029	Transistor	DTC114YUT106		R151	RK3049	Chip. R	ERJ3GSYJ822V	
Q110	XU0157	Transistor	UMD3(TR)		R152	RK3056	Chip. R	ERJ3GSYJ333V	E
Q112	XU0029	Transistor	DTC114YUT106		R152	RK3001	Chip. R	ERJ3GSY0R00V	T
Q113	XU0029	Transistor	DTC114YUT106		R153	RK1020	Chip. R	ERJ8GEYJ151V	
R101	RK1020	Chip. R	ERJ8GEYJ151V		R154	RA0009	Chip. R	EXBV8V102JV	
R102	RK3001	Chip. R	ERJ3GSY0R00V		R155	RA0009	Chip. R	EXBV8V102JV	
R103	RK3074	Chip. R	ERJ3GSYJ105V		R156	RK3010	Chip. R	ERJ3GSYJ4R7V	
R104	RK3074	Chip. R	ERJ3GSYJ105V		R157	RK1106	Chip. R	ERJ8GEYJ3R3V	
R105	RK3041	Chip. R	ERJ3GSYJ182V		R159	RK3058	Chip. R	ERJ3GSYJ473V	
R106	RK3028	Chip. R	ERJ3GSYJ151V		R160	RK3058	Chip. R	ERJ3GSYJ473V	
R107	RK3028	Chip. R	ERJ3GSYJ151V		R161	RK3059	Chip. R	ERJ3GSYJ563V	
R108	RK3038	Chip. R	ERJ3GSYJ102V		R162	RK3062	Chip. R	ERJ3GSYJ104V	
R109	RK3036	Chip. R	ERJ3GSYJ681V		R165	RK3001	Chip. R	ERJ3GSY0R00V	
R110	RK3062	Chip. R	ERJ3GSYJ104V		R170	RK3072	Chip. R	ERJ3GSYJ684V	
R111	RK3062	Chip. R	ERJ3GSYJ104V	E	R172	RK3061	Chip. R	ERJ3GSYJ823V	
R112	RK3065	Chip. R	ERJ3GSYJ184V		R173	RK3044	Chip. R	ERJ3GSYJ332V	
R113	RK3038	Chip. R	ERJ3GSYJ102V		R174	RK3044	Chip. R	ERJ3GSYJ332V	
R114	RK3058	Chip. R	ERJ3GSYJ473V		R175	RK3074	Chip. R	ERJ3GSYJ105V	
R115	RK3062	Chip. R	ERJ3GSYJ104V		S101	UR0002	Switch	EVQ-WQGF1524B	
R116	RK3001	Chip. R	ERJ3GSY0R00V		S102	UU0015	Switch	SKQD-901	
R117	RA0020	Chip. R	EXBV8V473JV		S103	UU0015	Switch	SKQD-901	
R118	RK3058	Chip. R	ERJ3GSYJ473V		S104	UU0015	Switch	SKQD-901	
R119	RK3058	Chip. R	ERJ3GSYJ473V		S105	UU0015	Switch	SKQD-901	
R120	RK3057	Chip. R	ERJ3GSYJ393V		S106	UU0015	Switch	SKQD-901	
R121	RK3045	Chip. R	ERJ3GSYJ392V		S107	UU0015	Switch	SKQD-901	
R122	RK3054	Chip. R	ERJ3GSYJ223V		S108	UU0015	Switch	SKQD-901	
R123	RK3046	Chip. R	ERJ3GSYJ472V		S109	UU0015	Switch	SKQD-901	
R124	RK3058	Chip. R	ERJ3GSYJ473V		S110	UU0015	Switch	SKQD-901	
R125	RA0008	Chip. R	EXBV4V102JV		S111	UQ0011	Switch	ESB-64801	
R126	RA0008	Chip. R	EXBV4V102JV		VR101	RV0020	Trim. Pot	RK09K1130-10KA	
R127	RA0009	Chip. R	EXBV8V102JV		VR102	RV0021	Trim. Pot	RK09K1130-10KB	
R128	RA0008	Chip. R	EXBV4V102JV		X101	XB0010	Crystal	CSAC4.00MGC100-TC	
R129	RK3038	Chip. R	ERJ3GSYJ102V		X102	XQ0045	Crystal	DSMAT3.58MHZ_18P	
R130	RK1020	Chip. R	ERJ8GEYJ151V			YZ0131		Filament Tape 12x1mm	
R131	RK3050	Chip. R	ERJ3GSYJ103V						
R132	RK4051	Chip. R	ERJ14YJ101H						
R133	RK3001	Chip. R	ERJ3GSY0R00V	T					
R134	RA0019	Chip. R	EXBV4V473JV						
R135	RA0008	Chip. R	EXBV4V102JV						
R136	RK3001	Chip. R	ERJ3GSY0R00V						
R137	RK3058	Chip. R	ERJ3GSYJ473V						
R138	RK3070	Chip. R	ERJ3GSYJ474V						
R139	RK3060	Chip. R	ERJ3GSYJ683V						
R140	RK3061	Chip. R	ERJ3GSYJ823V						
R141	RK3057	Chip. R	ERJ3GSYJ393V						

MAIN Unit

Ref. No.	Parts No.	Description	Parts Name	Ver.	Ref. No.	Parts No.	Description	Parts Name	Ver.
MAIN Unit									
C201	CC0061	Chip C.	CC45CH1H330JYA_F=2.5		C256	CU3035	Chip C.	C1608JB1H102KT-A	
C202	CC0061	Chip C.	CC45CH1H330JYA_F=2.5		C257	CS0049	Chip Tantal	TMCSA1C105MTR	
C203	CU3003	Chip C.	C1608CH1H020CT-A		C258	CS0063	Chip Tantal	TMCSA1V104MTR	
C204	CU3004	Chip C.	C1608CH1H030CT-A		C259	CU3035	Chip C.	C1608JB1H102KT-A	
C205	CU3011	Chip C.	C1608CH1H100CT-A		C260	CU3035	Chip C.	C1608JB1H102KT-A	
C206	CC0061	Chip C.	CC45CH1H330JYA_F=2.5		C261	CS0373	Chip Tantal	TMCMD1C476MTR	
C207	CU3035	Chip C.	C1608JB1H102KT-A		C262	CS0373	Chip Tantal	TMCMD1C476MTR	
C208	CU3035	Chip C.	C1608JB1H102KT-A		C263	CE0355	Electrolytic.C	25MV1000HC+T	
C210	CU3012	Chip C.	C1608CH1H120JT-A		C264	CU3035	Chip C.	C1608JB1H102KT-A	
C211	CU3035	Chip C.	C1608JB1H102KT-A		C265	CS0227	Chip Tantal	TMCMC1D106MTR	
C212	CS0227	Chip Tantal	TMCMC1D106MTR		C266	CU3035	Chip C.	C1608JB1H102KT-A	
C213	CS0227	Chip Tantal	TMCMC1D106MTR		C267	CU8042	Chip C.	C2012JB1C104KT-A	
C214	CU3035	Chip C.	C1608JB1H102KT-A		C268	CU3023	Chip C.	C1608CH1H101JT-A	
C215	CU3035	Chip C.	C1608JB1H102KT-A		C269	CU3035	Chip C.	C1608JB1H102KT-A	
C216	CU3088	Chip C.	C1608CH1H200JT-A		C270	CU3012	Chip C.	C1608CH1H120JT-A	
C217	CU3016	Chip C.	C1608CH1H270JT-A		C271	CU3047	Chip C.	C1608JB1H103KT-A	
C218	CU3035	Chip C.	C1608JB1H102KT-A		C272	CU3020	Chip C.	C1608CH1H560JT-A	
C219	CU3035	Chip C.	C1608JB1H102KT-A		C273	CU3022	Chip C.	C1608CH1H820JT-A	
C221	CU3035	Chip C.	C1608JB1H102KT-A		C274	CU3047	Chip C.	C1608JB1H103KT-A	
C222	CU3011	Chip C.	C1608CH1H100CT-A		C275	CU8042	Chip C.	C2012JB1C104KT-A	
C223	CU8042	Chip C.	C2012JB1C104KT-A		C276	CU8042	Chip C.	C2012JB1C104KT-A	
C224	CU3035	Chip C.	C1608JB1H102KT-A		C277	CU8042	Chip C.	C2012JB1C104KT-A	
C225	CS0221	Chip Tantal	TMCMB1C475MTR		C278	CU8042	Chip C.	C2012JB1C104KT-A	
C226	CU3014	Chip C.	C1608CH1H180JT-A		C279	CS0373	Chip Tantal	TMCMD1C476MTR	
C227	CU3019	Chip C.	C1608CH1H470JT-A		C280	CU8042	Chip C.	C2012JB1C104KT-A	
C228	CU3035	Chip C.	C1608JB1H102KT-A		C281	CU8042	Chip C.	C2012JB1C104KT-A	
C229	CU3035	Chip C.	C1608JB1H102KT-A		C282	CU3047	Chip C.	C1608JB1H103KT-A	
C230	CU3035	Chip C.	C1608JB1H102KT-A		C283	CU3047	Chip C.	C1608JB1H103KT-A	
C231	CU3035	Chip C.	C1608JB1H102KT-A		C284	CU8042	Chip C.	C2012JB1C104KT-A	
C232	CU3023	Chip C.	C1608CH1H101JT-A		C285	CU8042	Chip C.	C2012JB1C104KT-A	
C233	CU3035	Chip C.	C1608JB1H102KT-A		C286	CS0049	Chip Tantal	TMCSA1C105MTR	
C234	CU3006	Chip C.	C1608CH1H050CT-A		C287	CU8042	Chip C.	C2012JB1C104KT-A	
C235	CU3035	Chip C.	C1608JB1H102KT-A		C288	CU3047	Chip C.	C1608JB1H103KT-A	
C236	CU3035	Chip C.	C1608JB1H102KT-A		C289	CU8042	Chip C.	C2012JB1C104KT-A	
C237	CU3012	Chip C.	C1608CH1H120JT-A		C290	CU8042	Chip C.	C2012JB1C104KT-A	
C238	CU3009	Chip C.	C1608CH1H080CT-A		C291	CU3051	Chip C.	C1608JB1E223KT-A	
C239	CU3035	Chip C.	C1608JB1H102KT-A		C292	CU3047	Chip C.	C1608JB1H103KT-A	
C240	CU3035	Chip C.	C1608JB1H102KT-A		C293	CU3047	Chip C.	C1608JB1H103KT-A	
C241	CU3035	Chip C.	C1608JB1H102KT-A		C294	CS0063	Chip Tantal	TMCSA1V104MTR	
C242	CU3019	Chip C.	C1608CH1H470JT-A		C295	CU3047	Chip C.	C1608JB1H103KT-A	
C243	CU3009	Chip C.	C1608CH1H080CT-A		C296	CU3047	Chip C.	C1608JB1H103KT-A	
C244	CU3047	Chip C.	C1608JB1H103KT-A		C297	CU3035	Chip C.	C1608JB1H102KT-A	
C245	CS0372	Chip Tantal	TMCMB1C106MTR		C298	CS0372	Chip Tantal	TMCMB1C106MTR	
C246	CU3031	Chip C.	C1608JB1H471KT-A		C299	CU3051	Chip C.	C1608JB1E223KT-A	
C247	CU3031	Chip C.	C1608JB1H471KT-A	E	C301	CU3047	Chip C.	C1608JB1H103KT-A	
C248	CU3035	Chip C.	C1608JB1H102KT-A		C302	CU3001	Chip C.	C1608CH1H0R5CT-A	E
C249	CU3031	Chip C.	C1608JB1H471KT-A	E	C303	CU3003	Chip C.	C1608CH1H020CT-A	E
C250	CU3006	Chip C.	C1608CH1H050CT-A		C304	CU3002	Chip C.	C1608CH1H010CT-A	E
C251	CU3035	Chip C.	C1608JB1H102KT-A		C305	CU3031	Chip C.	C1608JB1H471KT-A	E
C252	CU3023	Chip C.	C1608CH1H101JT-A		C306	CU3013	Chip C.	C1608CH1H150JTA	
C253	CU3019	Chip C.	C1608CH1H470JT-A		C307	CU3035	Chip C.	C1608JB1H102KT-A	
C254	CU3019	Chip C.	C1608CH1H470JT-A		C308	CU8042	Chip C.	C2012JB1C104KT-A	
C255	CS0049	Chip Tantal	TMCSA1C105MTR		C309	GE0340	Electrolytic.C	16MV_47HW+TS	
					C310	GE0351	Electrolytic.C	16MV220HC	

Ref. No.	Parts No.	Description	Parts Name	Ver.	Ref. No.	Parts No.	Description	Parts Name	Ver.
C311	CE0340	Electrolytic.C	16MV_47HW+TS		D215	XD0107	Diode	G3B	
C312	CE0192	Electrolytic.C	16MV_470HW		D216	XD0130	Diode	DA204U(T106)	
C313	CE0355	Electrolytic.C	25MV1000HC+T		D217	XD0231	Diode	DAP202U(T106)	
C314	CU8042	Chip C.	C2012JB1C104KT-A		D219	XD0231	Diode	DAP202U(T106)	
C315	CU3035	Chip C.	C1608JB1H102KT-A		D220	XD0014	Diode	MI308	
C317	CU9009	Chip C.	C3216JB1H103KT-A		D221	XD0272	Diode	1SS356_TW11	
C318	CU3014	Chip C.	C1608CH1H180JT-A		D222	XD0272	Diode	1SS356_TW11	
C319	CU3003	Chip C.	C1608CH1H020CT-A		D224	XD0136	Diode	DTZ5.1A(TT11)	
C320	CU3035	Chip C.	C1608JB1H102KT-A		D225	XD0103	Diode	1SS226TE85L	
C321	CU3047	Chip C.	C1608JB1H103KT-A		IC201	XA0223	IC	TK10930VTL	
C322	CU3017	Chip C.	C1608CH1H330JT-A		IC202	XA0079	IC	μPC1241H	
C323	CU3035	Chip C.	C1608JB1H102KT-A		IC203	XA0267	IC	TA7806F(TE16L)	
C324	CU3035	Chip C.	C1608JB1H102KT-A		IC204	XA0264	IC	NJM7809A	
C325	CU3035	Chip C.	C1608JB1H102KT-A		IC205	XA0145	IC	MB1504LPF-G-BND-TF	
C326	CU3019	Chip C.	C1608CH1H470JT-A		IC206	XA0246	IC	BU4094BF-T1	
C327	CU3019	Chip C.	C1608CH1H470JT-A		IC207	XA0246	IC	BU4094BF-T1	
C328	CU3019	Chip C.	C1608CH1H470JT-A		J202	UE0041	Connector	TMP-J01X-V6	E
C329	CU3035	Chip C.	C1608JB1H102KT-A		J203	UE0191	Connector	11PS-JE	
C330	CU3047	Chip C.	C1608JB1H103KT-A		J204	UE0191	Connector	11PS-JE	
C331	CS0049	Chip Tantal	TMCSA1C105MTR		J205	UJ0024	Jack	HSJ1403-01-010	
C332	CU3010	Chip C.	C1608CH1H090CT-A		J206	UE0043	Connector	PI22A02M	
C333	CU3004	Chip C.	C1608CH1H030CT-A		J208	UJ0025	Jack	HSJ1462-01-010	
C334	CU3005	Chip C.	C1608CH1H040CT-A		L201	QKA35F	Coil	MR4.0x3.5Tx0.6	
C335	CU3035	Chip C.	C1608JB1H102KT-A		L202	QKA35F	Coil	MR4.0x3.5Tx0.6	
C336	CU3035	Chip C.	C1608JB1H102KT-A		L203	QA0098	Coil	KE-07318	
C337	CU3035	Chip C.	C1608JB1H102KT-A		L204	QKA35F	Coil	MR4.0x3.5Tx0.6	
C338	CU3035	Chip C.	C1608JB1H102KT-A		L205	QKA35F	Coil	MR4.0x3.5Tx0.6	
C339	CU3035	Chip C.	C1608JB1H102KT-A		L206	QKA95D	Coil	MR3.0_9.5T_0.6	
C340	CU3003	Chip C.	C1608CH1H020CT-A		L207	QKA35F	Coil	MR4.0x3.5Tx0.6	
C341	CU3035	Chip C.	C1608JB1H102KT-A		L208	QC0337	Coil	LQN2A56NM04	
C342	CU3035	Chip C.	C1608JB1H102KT-A		L209	QC0337	Coil	LQN2A56NM04	
C343	CS0372	Chip Tantal	TMCMB1C106MTR		L210	QC0337	Coil	LQN2A56NM04	
C350	CS0237	Chip Tantal	TMCMA1A475MTR		L211	QA0095	Coil	KE-07302	
C351	CU3035	Chip C.	C1608JB1H102KT-A		L212	QA0095	Coil	KE-07302	
C352	CS0232	Chip Tantal	TMCMA1V474MTR		L213	QA0096	Coil	KE-07303	
C353	CU3035	Chip C.	C1608JB1H102KT-A	E	L214	QA0095	Coil	KE-07302	
C354	CE0351	Electrolytic.C	16MV220HC		L215	QC0336	Coil	LQH3C1R0M04	
CF201	XC0016	Filter	CFWS455F		L216	QC0337	Coil	LQN2A56NM04	
D201	XD0295	Diode	UM9401-RK		L217	QC0249	Coil	LQN2A10NM04	E
D202	XD0014	Diode	MI308		L218	QC0337	Coil	LQN2A56NM04	
D203	XD0130	Diode	DA204U(T106)		L219	QC0336	Coil	LQH3C1R0M04	
D204	XD0130	Diode	DA204U(T106)		L220	QC0335	Coil	LQH3NR27M04	
D205	XD0128	Diode	MA713(TX)		L221	QA0097	Coil	KE-06813(IF-0342)	
D206	XD0272	Diode	1SS356_TW11		L222	QC0249	Coil	LQN2A10NM04	E
D207	XD0131	Diode	1SV214(TPH4)		L223	QC0249	Coil	LQN2A10NM04	E
D208	XD0131	Diode	1SV214(TPH4)		L224	QC0337	Coil	LQN2A56NM04	E
D209	XD0131	Diode	1SV214(TPH4)		L225	QC0251	Coil	LQN2A22NM04	
D210	XD0131	Diode	1SV214(TPH4)		L226	QC0251	Coil	LQN2A22NM04	
D211	XD0272	Diode	1SS356_TW11						
D212	XD0272	Diode	1SS356_TW11						
D213	XD0272	Diode	1SS356_TW11	E					
D214	XD0272	Diode	1SS356_TW11						

MAIN Unit

Ref. No.	Parts No.	Description	Parts Name	Ver.	Ref. No.	Parts No.	Description	Parts Name	Ver.
Q201	XT0122	Transistor	2SC4116GR(TE85L)		R218	RK3018	Chip R.	ERJ3GSYJ220V	
Q202	XT0084	Transistor	2SC2954-T1		R219	RK3038	Chip R.	ERJ3GSYJ102V	
Q203	XT0092	Transistor	2SA1307Y		R220	RK3026	Chip R.	ERJ3GSYJ101V	
Q204	XT0122	Transistor	2SC4116GR(TE85L)		R221	RK3062	Chip R.	ERJ3GSYJ104V	
Q205	XU0159	Transistor	UMS1(TR)		R222	RK3062	Chip R.	ERJ3GSYJ104V	
Q206	XT0119	Transistor	2SC3356-T1B(R24)		R223	RK3026	Chip R.	ERJ3GSYJ101V	
Q207	XT0141	Transistor	2SC4226-T1_R24		R224	RK3022	Chip R.	ERJ3GSYJ470V	
Q208	XT0141	Transistor	2SC4226-T1_R24		R225	RK3062	Chip R.	ERJ3GSYJ104V	
Q209	XE0023	Transistor	3SK151GR(TE85L)		R226	RK3062	Chip R.	ERJ3GSYJ104V	
Q210	XT0141	Transistor	2SC4226-T1_R24		R227	RK3062	Chip R.	ERJ3GSYJ104V	
Q211	XU0099	Transistor	2SA1736(TE12L)		R228	RK3062	Chip R.	ERJ3GSYJ104V	
Q212	XU0029	Transistor	DTC114YUT106		R229	RK3058	Chip R.	ERJ3GSYJ473V	
Q213	XT0120	Transistor	2SA1586-GR(TE85L)		R230	RK3054	Chip R.	ERJ3GSYJ223V	
Q214	XT0124	Transistor	2SC4215Y(TE85L)		R231	RK3022	Chip R.	ERJ3GSYJ470V	
Q215	XT0122	Transistor	2SC4116GR(TE85L)		R232	RK3070	Chip R.	ERJ3GSYJ474V	
Q216	XT0105	Transistor	2SC4213A(TE85L)		R233	RK3070	Chip R.	ERJ3GSYJ474V	
Q217	XT0122	Transistor	2SC4116GR(TE85L)		R234	RK3070	Chip R.	ERJ3GSYJ474V	
Q218	XT0122	Transistor	2SC4116GR(TE85L)		R235	RK3022	Chip R.	ERJ3GSYJ470V	
Q219	XT0100	Transistor	2SC3585-T1B(R/R44)	E	R236	RK3054	Chip R.	ERJ3GSYJ223V	
Q220	XU0161	Transistor	XP1114-(TX)		R237	RK3022	Chip R.	ERJ3GSYJ470V	E
Q221	XU0161	Transistor	XP1114-(TX)	E	R238	RK3046	Chip R.	ERJ3GSYJ472V	E
Q222	XU0161	Transistor	XP1114-(TX)		R239	RK3038	Chip R.	ERJ3GSYJ102V	
Q223	XU0161	Transistor	XP1114-(TX)		R240	RK3068	Chip R.	ERJ3GSYJ334V	
Q224	XU0029	Transistor	DTC114YUT106		R241	RK3022	Chip R.	ERJ3GSYJ470V	
Q225	XU0029	Transistor	DTC114YUT106		R242	RK3041	Chip R.	ERJ3GSYJ182V	
Q226	XU0153	Transistor	UMG7(TR)		R243	RK3046	Chip R.	ERJ3GSYJ472V	
Q227	XU0153	Transistor	UMG7(TR)		R244	RK4065	Chip R.	ERJ14YJ102H	
Q228	XU0153	Transistor	UMG7(TR)		R245	RK3050	Chip R.	ERJ3GSYJ103V	
Q229	XU0155	Transistor	DTB123YK(T146)		R246	RK3030	Chip R.	ERJ3GSYJ221V	
Q230	XU0155	Transistor	DTB123YK(T146)		R247	RK3056	Chip R.	ERJ3GSYJ333V	
Q231	XU0029	Transistor	DTC114YUT106		R248	RK3062	Chip R.	ERJ3GSYJ104V	
Q232	XU0029	Transistor	DTC114YUT106		R249	RK3050	Chip R.	ERJ3GSYJ103V	
Q233	XU0029	Transistor	DTC114YU T106		R250	RK3038	Chip R.	ERJ3GSYJ102V	
Q234	XT0141	Transistor	2SC4226-T1_R24		R251	RK3022	Chip R.	ERJ3GSYJ470V	
Q235	XE0019	FET	2SJ144-Y_TE85R		R252	RK3033	Chip R.	ERJ3GSYJ391V	
Q238	XU0029	Transistor	DTC114YUT106		R253	RK3068	Chip R.	ERJ3GSYJ334V	
R201	RK3062	Chip R.	ERJ3GSYJ104V		R254	RK3054	Chip R.	ERJ3GSYJ223V	
R202	RK3018	Chip R.	ERJ3GSYJ220V		R255	RK3047	Chip R.	ERJ3GSYJ562V	
R203	RK4062	Chip R.	ERJ14YJ100H		R256	RK3050	Chip R.	ERJ3GSYJ103V	
R204	RK3059	Chip R.	ERJ3GSYJ563V		R257	RK3046	Chip R.	ERJ3GSYJ472V	
R205	RK3062	Chip R.	ERJ3GSYJ104V		R258	RK3044	Chip R.	ERJ3GSYJ332V	
R206	RK3018	Chip R.	ERJ3GSYJ220V		R259	RK3070	Chip R.	ERJ3GSYJ474V	
R207	RK3042	Chip R.	ERJ3GSYJ222V		R260	RK3038	Chip R.	ERJ3GSYJ102V	
R208	RK3054	Chip R.	ERJ3GSYJ223V		R261	RK3022	Chip R.	ERJ3GSYJ470V	
R209	RK4064	Chip R.	ERJ14YJ471H		R262	RK3030	Chip R.	ERJ3GSYJ221V	
R210	RK3034	Chip R.	ERJ3GSYJ471V		R263	RK3050	Chip R.	ERJ3GSYJ103V	
R211	RK3047	Chip R.	ERJ3GSYJ562V		R264	RK3031	Chip R.	ERJ3GSYJ271V	
R212	RK3050	Chip R.	ERJ3GSYJ103V		R265	RK3038	Chip R.	ERJ3GSYJ102V	
R213	RK3050	Chip R.	ERJ3GSYJ103V		R266	RK3022	Chip R.	ERJ3GSYJ470V	
R214	RK3050	Chip R.	ERJ3GSYJ103V		R267	RK3070	Chip R.	ERJ3GSYJ474V	
R215	RK3042	Chip R.	ERJ3GSYJ222V		R268	RK3046	Chip R.	ERJ3GSYJ472V	
R216	RK3042	Chip R.	ERJ3GSYJ222V		R269	RK3046	Chip R.	ERJ3GSYJ472V	
R217	RK3033	Chip R.	ERJ3GSYJ391V		R270	RK3026	Chip R.	ERJ3GSYJ101V	
					R271	RK3056	Chip R.	ERJ3GSYJ333V	

Ref. No.	Parts No.	Description	Parts Name	Ver.	Ref. No.	Parts No.	Description	Parts Name	Ver.
R272	RK3053	Chip R.	ERJ3GSYJ183V		TH202	XS0027	Thermistor	TBPS1R154K475H5Q	
R273	RK3042	Chip R.	ERJ3GSYJ222V		VR201	RH0118	Trim. Pot	RH03A3AS3X	
R274	RK3022	Chip R.	ERJ3GSYJ470V		VR202	RH0118	Trim. Pot	RH03A3AS3X	
R275	RK3070	Chip R.	ERJ3GSYJ474V		VR203	RH0118	Trim. Pot	RH03A3AS3X	
R276	RK3072	Chip R.	ERJ3GSYJ684V		VR204	RH0118	Trim. Pot	RH03A3AS3X	
R277	RK3054	Chip R.	ERJ3GSYJ223V		VR205	RH0120	Trim. Pot	RH03A3AS4X	
R278	RK3070	Chip R.	ERJ3GSYJ474V		VR206	RH0125	Trim. Pot	RH03A3AS5X	
R279	RK3050	Chip R.	ERJ3GSYJ103V						
R280	RK3066	Chip R.	ERJ3GSYJ224V	E	X201	XQ0061	Crystal	12.8MHz_UM1	
R281	RK3034	Chip R.	ERJ3GSYJ471V	E	X202	XQ0062	Crystal	44.645MHz_UM1	
R282	RK3022	Chip R.	ERJ3GSYJ470V	E	X203	XF0016	Filter	45N15B1H	
R283	RK3055	Chip R.	ERJ3GSYJ273V						
R284	RK1109	Chip R.	ERJ8GEYJ1R0V						
R285	RK3026	Chip R.	ERJ3GSYJ101V			SD0034		Earth Spring	
R286	RK3050	Chip R.	ERJ3GSYJ103V			TT1001	Tube	0.7ø	
R287B	RF0004		1W_68Ω			TT3008	Tube	Sumi Tube_4.0_1mm	
R288	RK3047	Chip R.	ERJ3GSYJ562V			TZ0058		Silicon Dumper_XM569	
R289	RK3058	Chip R.	ERJ3GSYJ473V			UX1072A	Wire		
R290	RK3058	Chip R.	ERJ3GSYJ473V			YZ0058	Wire	0.4ø	
R291	RK3050	Chip R.	ERJ3GSYJ103V						
R292	RK3050	Chip R.	ERJ3GSYJ103V						
R293	RK3050	Chip R.	ERJ3GSYJ103V						
R294	RK3050	Chip R.	ERJ3GSYJ103V						
R295	RK3050	Chip R.	ERJ3GSYJ103V						
R296	RK3050	Chip R.	ERJ3GSYJ103V						
R297	RK3050	Chip R.	ERJ3GSYJ103V						
R298	RK3050	Chip R.	ERJ3GSYJ103V						
R299	RK3062	Chip R.	ERJ3GSYJ104V						
R300	RK3038	Chip R.	ERJ3GSYJ102V						
R301	RK3078	Chip R.	ERJ3GSYJ225V						
R302	RK3038	Chip R.	ERJ3GSYJ102V						
R303	RK3061	Chip R.	ERJ3GSYJ823V						
R304	RK3062	Chip R.	ERJ3GSYJ104V						
R305	RK3037	Chip R.	ERJ3GSYJ821V						
R306	RK0052	Chip R.	ERJ6GEYJ103V						
R307	RK3046	Chip R.	ERJ3GSYJ472V						
R308	RK3048	Chip R.	ERJ3GSYJ682V						
R309	RK3062	Chip R.	ERJ3GSYJ104V						
R313	RK3057	Chip R.	ERJ3GSYJ393V						
R314	RK3001	Chip R.	ERJ3GSY0R00V						
R315	RK3022	Chip R.	ERJ3GSYJ470V						
R316	RK3044	Chip R.	ERJ3GSYJ332V						
R317	RK3030	Chip R.	ERJ3GSYJ221V						
R318	RK3042	Chip R.	ERJ3GSYJ222V						
R319	RK3037	Chip R.	ERJ3GSYJ821V						
R320	RK3039	Chip R.	ERJ3GSYJ122V						
R321	RK3001	Chip R.	ERJ3GSY0R00V						
R323	RK3058	Chip R.	ERJ3GSYJ473V						
R324	RK3068	Chip R.	ERJ3GSYJ334V						
R325	RK3001	Chip R.	ERJ3GSY0R00V						
R326	RK3029	Chip R.	ERJ3GSYJ181V						
R327	RK3001	Chip R.	ERJ3GSY0R00V						
TC201	CT0030	Trimmer	CTZ-20CW						

VCO Unit / SP Unit

Ref. No.	Parts No.	Description	Parts Name	Ver.	Ref. No.	Parts No.	Description	Parts Name	Ver.
VCO Unit					R401	RK3046	Chip R.	ERJ3GSYJ472V	
C401	CU3035	Chip C.	C1608JB1H102KT-A		R402	RK3048	Chip R.	ERJ3GSYJ682V	
C402	CU3001	Chip C.	C1608CH1H0R5CT-A		R403	RK3058	Chip R.	ERJ3GSYJ473V	
C403	CU3019	Chip C.	C1608CH1H470JT-A		R404	RK3034	Chip R.	ERJ3GSYJ471V	
C404	CU3012	Chip C.	C1608CH1H120JT-A		R406	RK3058	Chip R.	ERJ3GSYJ473V	
C405	CU3016	Chip C.	C1608CH1H270JT-A		R407	RK3046	Chip R.	ERJ3GSYJ472V	
C406	CU3031	Chip C.	C1608JB1H471KT-A		R408	RK3042	Chip R.	ERJ3GSYJ222V	
C407	CS0372	Chip Tantal	TMCMB1C106MTR		R409	RK3058	Chip R.	ERJ3GSYJ473V	
C408	CU3031	Chip C.	C1608JB1H471KT-A		R410	RK3046	Chip R.	ERJ3GSYJ472V	
C409	CS0372	Chip Tantal	TMCMB1C106MTR		R411	RK3048	Chip R.	ERJ3GSYJ682V	
C410	CU3035	Chip C.	C1608JB1H102KT-A		R412	RK3058	Chip R.	ERJ3GSYJ473V	
C411	CU3035	Chip C.	C1608JB1H102KT-A		R413	RK3034	Chip R.	ERJ3GSYJ471V	
C412	CU3035	Chip C.	C1608JB1H102KT-A		R414	RK3022	Chip R.	ERJ3GSYJ470V	
C413	CU3001	Chip C.	C1608CH1H0R5CT-A		R415	RK3046	Chip R.	ERJ3GSYJ472V	
C414	CU3023	Chip C.	C1608CH1H101JT-A		R416	RK3058	Chip R.	ERJ3GSYJ473V	
C415	CU3016	Chip C.	C1608CH1H270JT-A		R417	RK3065	Chip R.	ERJ3GSYJ184V	
C416	CU3023	Chip C.	C1608CH1H101JT-A		R418	RK3026	Chip R.	ERJ3GSYJ101V	
C417	CU3035	Chip C.	C1608JB1H102KT-A		R419	RK3022	Chip R.	ERJ3GSYJ470V	
C418	CS0372	Chip Tantal	TMCMB1C106MTR		R420	RK3022	Chip R.	ERJ3GSYJ470V	
C419	CU3035	Chip C.	C1608JB1H102KT-A			TS0096		VCO Case	
C420	CS0372	Chip Tantal	TMCMB1C106MTR		SP Unit				
C421	CU3003	Chip C.	C1608CH1H020CT-A			ES0007	Speaker	VS-57-0814-1.5W	
C422	CU3003	Chip C.	C1608CH1H020CT-A			FG0040		Speaker Cushion	
C423	CU3035	Chip C.	C1608JB1H102KT-A			UX1047	Wire		
C424	CU3035	Chip C.	C1608JB1H102KT-A						
C425	CU3035	Chip C.	C1608JB1H102KT-A						
D401	XD0132	Diode	1SV215 (TPH4)						
D402	XD0132	Diode	1SV215 (TPH4)						
D403	XD0131	Diode	1SV214 (TPH4)						
D404	XD0132	Diode	1SV215 (TPH4)						
D405	XD0132	Diode	1SV215 (TPH4)						
D406	XD0131	Diode	1SV214 (TPH4)						
L401	QC0092A	Coil	KS12-175-1A						
L402	QA0094A	Coil	KE-07304A						
P401	UE0211	Connector	9207B-1-02Z-T						
P402	UE0211	Connector	9207B-1-02Z-T						
P403	UE0212	Connector	9207B-1-07Z-T						
PC101	UP0257	P.C.B.							
Q401	XT0141	Transistor	2SC4226-T1_R24						
Q402	XT0141	Transistor	2SC4226-T1_R24						
Q403	XT0141	Transistor	2SC4226-T1_R24						
Q404	XT0105	Transistor	2SC4213A(TE85L)						

MIC Unit / Mechanical Parts

Ref. No.	Parts No.	Description	Parts Name	Ver.	Ref. No.	Parts No.	Description	Parts Name	Ver.
MIC Unit					Mechanical Parts				
C501	CU3047	Chip C.	C1608JB1H103KT-A		AD0010		Screw	D3+8FeNi	
C502	CU8042	Chip C.	C2012JB1C104KT-A		AE0014		Screw	B2.6+8FeBG	
C503	CU3039	Chip C.	C1608JB1H222KT-A		AK0003		Screw	0B2.6+6FeNi1	
C504	CU3035	Chip C.	C1608JB1H102KT-A		AV0001		Screw	B2.6+6FeNi1	
C505	CU3035	Chip C.	C1608JB1H102KT-A		FF0015			Light Shield Cloth	
C506	CU3035	Chip C.	C1608JB1H102KT-A		FF0021			Volume Cloth	
C507	CU3024	Chip C.	C1608CH1H121JT-A		FF0028			Cloth 10x22	
C508	CS0049	Chip Tantal	TMCSA1C105MTR		FF0030			Cloth 5x20	
C509	CS0049	Chip Tantal	TMCSA1C105MTR		FF0031			Cloth 7x30	
C510	CU3043	Chip C.	C1608JB1H472KT-A		FG0147			Rubber Cushion DR130	
C511	CU3043	Chip C.	C1608JB1H472KT-A		FM0076			IC Spring	
C512	CS0372	Chip Tantal	TMCMB1C106MTR		FM0083			Washer DR130	
C513	CS0372	Chip Tantal	TMCMB1C106MTR		FP0080			Blind Plate	
C514	CU3035	Chip C.	C1608JB1H102KT-A		ND0004			Dial Cover	
C515	CU3024	Chip C.	C1608CH1H121JT-A		ND0020			Volume Rubber	
C516	CS0372	Chip Tantal	TMCMB1C106MTR		NK0009B			Dial Knob	
IC501	XA0265	IC	NJM2902M(T1)		NK0035			Volume Knob	
IC502	XA0332	IC	TA75S01F(TE85L)		NP0072			Power Switch Knob	
P501	UE0203	Connector	MB08P-90		NP0073			H/L Knob	
R501	RK3050	Chip R.	ERJ3GSYJ103V		KS0041B			Bottom Case	
R502	RK3048	Chip R.	ERJ3GSYJ682V		KZ0009A			Top Case	
R503	RK3073	Chip R.	ERJ3GSYJ824V		KZ0010A			Front Panel DR150T	T
R504	RK3056	Chip R.	ERJ3GSYJ333V		KZ0011A			Front Panel DR150E	E
R505	RK3062	Chip R.	ERJ3GSYJ104V		SS0053			Chassis	
R506	RK3052	Chip R.	ERJ3GSYJ153V		UA0037			R-B2.0x0.2M Plug 15A	
R507	RK3068	Chip R.	ERJ3GSYJ334V		UE0257			A30-30190-15	
R508	RK3048	Chip R.	ERJ3GSYJ682V		SD0050			Earth Spring	
R509	RK3078	Chip R.	ERJ3GSYJ225V		TS0083			Front Shield Case	
R510	RK3054	Chip R.	ERJ3GSYJ223V		XA0185			S-AV17	
R511	RK3054	Chip R.	ERJ3GSYJ223V		#P0798			Speaker Unit	
R512	RK3061	Chip R.	ERJ3GSYJ823V						
R513	RK3050	Chip R.	ERJ3GSYJ103V						
R514	RK3047	Chip R.	ERJ3GSYJ562V						
R515	RK3049	Chip R.	ERJ3GSYJ822V						
R516	RK3061	Chip R.	ERJ3GSYJ823V						
R517	RK3066	Chip R.	ERJ3GSYJ224V						
R518	RK3051	Chip R.	ERJ3GSYJ123V						
R519	RK3061	Chip R.	ERJ3GSYJ823V						
R520	RK3045	Chip R.	ERJ3GSYJ392V						

Others / Packing / Mic. Hanger Unit / EJ20u

Ref. No.	Parts No.	Description	Parts Name	Ver.	Ref. No.	Parts No.	Description	Parts Name	Ver.
Others					EJ20u				
	EHM35B		Microphone	E	C501	CS0236	Chip Tantal	TMCMAOJ685MTR	
	EHM39		Microphone	T	C502	CU3059	Chip C.	C1608JF1E104ZTA	
	DS0351		Spec. Sheet (M/D)		C503	CS0230	Chip Tantal	TMCMA1E105MTR	
	PF0024		Operation Sheet		C504	CU3059	Chip C.	C1608JF1E104ZTA	
	PF0030		Operation Card		C505	CS0230	Chip Tantal	TMCMA1E105MTR	
	PH0009		Registration Card	T	C506	CS0230	Chip Tantal	TMCMA1E105MTR	
	PR0237		FCC Part15 Seal		C507	CS0230	Chip Tantal	TMCMA1E105MTR	
	#G0598		Mic. Hanger Unit		C508	CU3023	Chip C.	C1608CH1H101JTA	
					C509	CS0237	Chip Tantal	TMCMA1A475MTR	
Packing						C510	CU3019	Chip C.	C1608CH1H470JTA
	DK0115		Acrylic Protection Seal		C511	CU3035	Chip C.	C1608JB1H102KTA	
	FM0078		Bracket		C512	CU3015	Chip C.	C1608CH1H220KTA	
	HK0329		Item Carton DR150		C513	CU3015	Chip C.	C1608CH1H220KTA	
	HM0141		Item Carton DR610 5sets		CN501	UX1050	Wire	EJ20u	
	HP0002	(Instr. Manu.)	Protect. Bag		IC501	XA0239	IC	AK2341	
	HP0037	(Bracket)	Protect. Bag		Q501	XT0095	Tansistor	2SC4081 T106R	
	HP0035	(Radio)	Protect. Bag		R501	RK3040	Chip R.	ERJ3GSYJ152V	
	HU0069		Fixture DR610		R502	RK3022	Chip R.	ERJ3GSYJ470V	
	HU0075		Fixture DR150		R503	RK3067	Chip R.	ERJ3GSYJ274V	
	HU0077		Fixture DR610T 5sets		R504	RK3038	Chip R.	ERJ3GSYJ102V	
	PK0049		Schematic Diagram		R505	RK3051	Chip R.	ERJ3GSYJ123V	
	PS0208		Instruction Manu. 150T		R506	RK3089	Chip R.	ERJ3GSYJ912V	
	PT0004A		Lot Number Seal		R507	RK3067	Chip R.	ERJ3GSYJ274V	
	UA0038		R-B2.0x3M Receptacle 15A		R508	RK3047	Chip R.	ERJ3GSYJ562V	
	YZ0118		Tape 50mm		R509	RK3068	Chip R.	ERJ3GSYJ334V	
	YZ0121		Tape 10mm		R510	RK3054	Chip R.	ERJ3GSYJ223V	
	#G0508		Power Cable		R511	RK3054	Chip R.	ERJ3GSYJ223V	
	#G0509		Screw Set 130T		R512	RK3055	Chip R.	ERJ3GSYJ273V	
Mic. Hanger Unit (#G0598)					R513	RK3074	Chip R.	ERJ3GSYJ105V	
	AA0013	Screw	M5+20FeCr		R514	RK3066	Chip R.	ERJ3GSYJ224V	
	AE0012	Screw	Fe3PMx880		R515	RK3048	Chip R.	ERJ3GSYJ682V	
	AN0002	Nut	Nut M-5FeCr		VR501	RH0106	Trim. Pot	EVM1YSX50BQ4	
	AJ0003	Screw	M5+20FeCr		X501	XQ0057	Crystal	DS-MAT 3.6864MHz	
	AZ0009	Washer	SW-5FeCr			HK0305		Carton	
	AZ0010		W-5FeCr			HP0029		Protection Bag	
	EF0005	Fuse	FGB015A			PG0057		Rubber Cushion	
	FM0079		Spanner			UP0243		P.C.B.	
						YZ0042	Adhesion	Bond G17	

ADJUSTMENT

1) Required Test Equipment

1. Regulated Power Supply

Supply voltage: DC11V~DC17V
Current: 15A or more

2. Digital Multimeter

Voltage range: FS = 20V or so
Current: 10A or more
Input resistance: High Impedance

3. Oscilloscope

Measurable frequency: Audio Frequency

4. Audio Dummy Load

Impedance: 8Ω
Dissipation: 3W or more
Jack: 3.5ø

5. SSG

Output frequency: 1GHz or more
Output level: -20dB/0.1μV to 120dB/1V
Moduration: AM/FM

6. Spectrum Analyzer

Measuring range: Up to 2GHz or more

7. Tracking Generator

Output frequency: Up to 2GHz or more

8. Power Meter

Measurable frequency: Up to 500MHz
Impedance: 50Ω, unbalanced
Measuring range: 0.5W~60W

9. Audio Voltmeter

Measurable frequency: ~100kHz
Sensitivity: 1mV ~ 10V

10. Audio Generator

Output frequency: 67Hz~10kHz
Output impedance: 600Ω, unbalanced

11. Distortion Meter/SINAD Meter

Measurable frequency: 1kHz
Input level: Up to 40dB
Distortion level: 1% ~100%

12. Frequency Counter

Measurable frequency: Up to 500MHz
Measurements stability: +/-0.1ppm or so

13. Linear Detector

Measurable frequency: Up to 500MHz
Characteristics: Flat
CN: 60dB or more

Note

1. Standard Modulation: 1kHz +/- 3.5kHz/DEV
2. Reference Sensitivity: 12dB SINAD
3. Specified Audio Output level: 1.5W at 8Ω
4. Standard Audio Output level: 0.75W at 8Ω
5. Use the following RF cable for the test equipmet:
5D2W x1m
6. Attach the fuse to the RF test equipment.
7. All SSG output is indicated by EMF.

2) Adjustment for DR-150T/E

Item	Condition		Measurement			Adjustment			Specifications
		TX/RX	Equipment	Unit	Terminal	Unit	Parts	Method	
Reference Frequency	f=145.00MHz	TX LOW	Freq. Counter Power Meter	Back	ANT	Main	TC201	145MHz	145MHz +/- 50Hz
PLL VCV	f=145.00MHz	RX	Digital Multimeter	Main	VCV	VCO	L402	DC4.6V	DC4.6V+/-0.1V
	f=145.00MHz	TX					—	Check	DC2.7V+/-0.8V
	f=433.00MHz	RX					L401	DC1.5V	DC1.5V+/-0.1V
Sensitivity	f=144.03MHz Std. Mod. Std. Audio output SSG OUT: -9.5dB μ	RX	SSG Dist. Meter	Main	ANT	Main	L211 L212 L214	SINAD MAX	Turn the coils L211, L212, L214 to the max order
	f=173.97MHz SSG OUT: +8dB μ						L213	SINAD MAX	SINAD is above12dB.
S Meter	f=145.03MHz (E) f=146.03MHz (T) Mod: OFF SSG OUT: 20dB μ	RX	SSG	S Meter	ANT	Main	VR206	"Full"	
	SSG OFF						—	Check	Does not light.
Distortion	f=145.03MHz (E) f=146.03MHz (T) Std. Mod. SSG OUT: 60dB μ	RX	SSG Dist. Meter	Main	ANT	Main	L221		Below 3%
High Power	f=144.98MHz (E) f=145.98MHz (T)	TX High	Power Meter	Back	ANT	Main	VR202	50W	50W+/-1W
		TX MID					VR201	25W	25W+/-1W
DEV	f=144.98MHz (f=145.98MHz) Mod: 1kHz Mic: -33dBm	TX LOW	Linear Det. Oscilloscope Power Meter	Back	ANT	Main	VR204	4.3kHz /DEV	4.3kHz +/-0.1kHz /DEV
Mic Gain	f=144.98MHz (E) f=145.98MHz (T) Mod: 1kHz Mic: -53dBm						VR203	3.5kHz /DEV	3.5 kHz +/-0.1kHz /DEV
CTCSS TONE 88.5Hz	f=144.98MHz (E) f=145.98MHz (T) Mod: OFF ENC Tone ON						VR205	0.7kHz /DEV	0.7kHz +/-0.1kHz /DEV

3) Adjustment Points

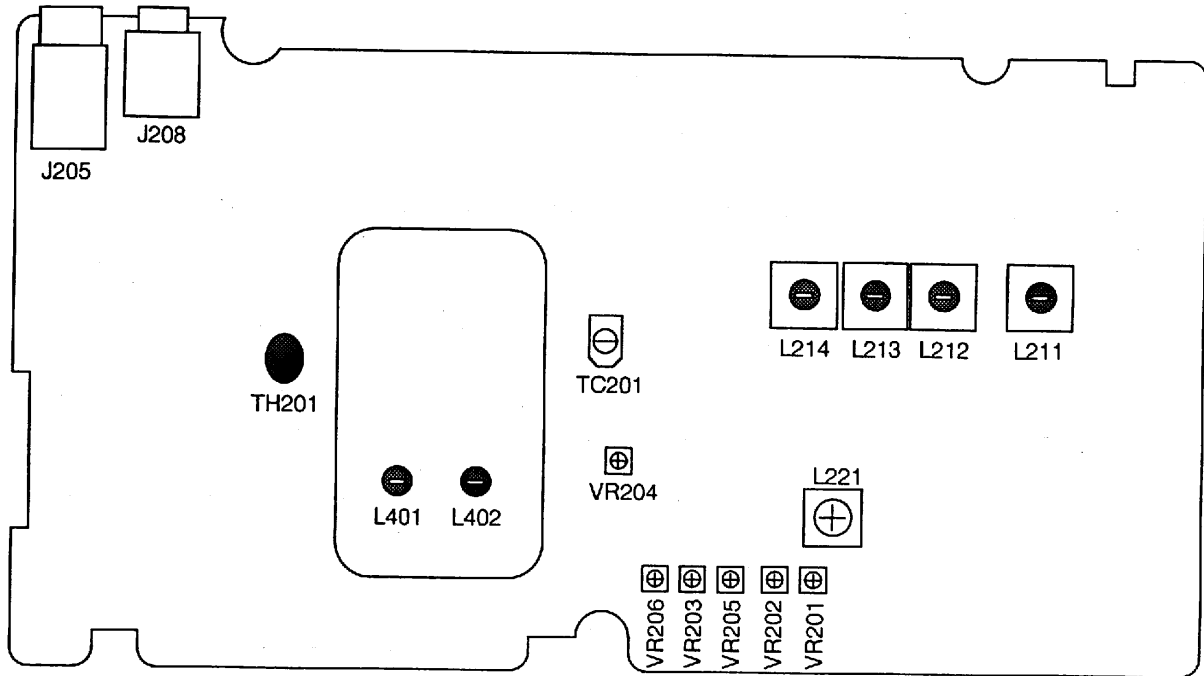

4) Adjustment Quick Reference

Parts	Item	Specifications
L211	RX Sensitivity	-9.5dB μ V (12dB SINAD)
L212	RX Sensitivity	-9.5dB μ V (12dB SINAD)
L213	RX Sensitivity	+8dB μ V (12dB SINAD)
L214	RX Sensitivity	-9.5dB μ V (12dB SINAD)
L221	RX Distortion	below 3%
L401	433MHz VCO Freq.	1.5V +/-0.1V
L402	145MHz VCO Freq.	4.6V +/-0.1V
TC201	Reference Frequency	145.00MHz +/-50Hz
VR201	TX Mid Power	25W +/-1.0W
VR202	TX High Power	50W +/-1.0W
VR203	Mic Gain	3.5kHz +/-0.1kHz
VR204	Deviation	4.3kHz +/-0.1kHz
VR205	CTCSS Tone	0.7kHz +/-0.1kHz
VR206	S Meter	20dB μ "Full"

VOLTAGE TABLE

Test Condition

The following measured voltage is the value soon after the reset operation (turning the power ON while pressing "F" key).

- 1) Frequency: Main channel
- 2) Transmitting Power: Low
- 3) Volume and squelch: The direction of 10 o'clock.
- 4) H=8.7V~8.9V, L=0V~0.2V
- 5) (L): Left, (R): Right, (U): Upper, (L): Lower

1) Transistor, FET

Ref. No.	Parts Name	RX Voltage			TX Voltage		
		B	C	E	B	C	E
Q201	2SC4116	0	0	0	0	0.6	0
Q202	2SC2954	0	0	0	2.5	4.8	1.3
Q203	2SA1307	13.7	0	13.7	13.1	6.4 (H) 5.5 (M) 4.5 (L)	13.7
Q204	2SC4226	0	13.7	0	0.6	12.8	0
Q205 (R)	UMS1	0	0	0	0.2	0.6	0.8
Q205 (L)	UMS1	0	0	0	0.3	0	0.8
Q206	2SC3356	0	0	0	2.5	9.1	1.3
Q207	2SC4226	0.7	7.6	0	0.7	7.4	0
Q208	2SC4226	0.7	8.4	0	0	0	0
Q209	3SK151	0 (G1) 0.8 (G2)	8.7 (D)	0 (S)	0 (G1) 0 (G2)	0 (D)	0 (S)
Q210	2SC4226	0.7	6.2	0	0.7	6.2	0
Q211	2SA1736	13.0	13.7	13.7	13.0	13.7	13.7
Q212	DTC114YU	13.7	0	0	13.7	0	0
Q213	2SA1586	5.9	0	5.6	5.9	0	5.6
Q214	2SC4215	0.7	8.0	0	0	0	0
Q215	2SC4116	1.7	8.7	1.1	0	0	0
Q216	2SC4213A	0.7	0	0	0	0	0
Q217	2SC4116	0	0	0	0	0	0
Q218	2SC4116	0.6	3.9	0	0	0	0
Q220 (U)	XP1114	L	8.8	8.9	H	0	8.9
Q222 (U)	XP1114	H	0	7.5	H	0	7.5
Q222 (L)	XP1114	L	7.5	7.5	H	7.5	7.5
Q223 (U)	XP1114	0	0	8.9	0	0	8.9
Q223 (L)	XP1114	0	8.9	8.9	0	8.9	8.9
Q224	DTC114YU	8.8	0	0	8.8	0	0
Q225	DTC114YU	0	0	0	0	0	0
Q226~8 (U)	UMG7	-	0	0	-	0	0
Q226~8 (L)	UMG7	0	4.7	0	0	4.7	0
Q229	DTB123YK	8.9	0	8.9	0	8.9	8.9
Q230	DTB123YK	0	8.9	8.9	8.9	0.4	8.9
Q231	DTC114YU	5	0	0	0.6	8.9	0
Q232	DTC114YU	0	0.7	0	0	0	0
Q233	DTC114YU	0	0.7	0	0	0.7	0
Q234	2SC4226	0	0.7	0	0	0	0
Q235	2SJ144	7.3 (G)	0 (D)	0 (S)	0 (G)	0 (D)	0 (S)
Q238	DTC114YU	0	0	0	0	0.2	0

2) Diode

Ref. No.	Parts Name	RX Voltage		TX Voltage	
		A	K	A	K
D201	UM9401	0	0	1.5	0.75
D202	MI308	0	0	0.75	0
D203 (R)	DA204U	-	0	-	0
D204 (R)	DA204U	0	0	-	7.0
D205 (U)	MA713	0	8.9	0.2	8.9
D205 (L)	MA713	0	8.9	0.2	0
D206	1SS356	0	7.6	8.1	7.4
D207~10	1SV214	0	4.3	0	2.5
D211	1SS356	8.7	8.0	0	0
D212	1SS356	8.4	7.6	0	7.4
D213	1SS356	0	7.6	0	7.4
D214	1SS356	0	7.6	0	7.4
D215	G3B	0	13.7	0	13.7
D216 (L)	DA204U	2.3	3.6	0	0
D217 (L)	DAP202U	6.0	5.6	6.0	5.6
D219 (U)	DAP202U	5	8.9	0.6	0
D220	MI308	1.4	0.7	0	0
D221	1SS356	0.7	0	0	0
D222	1SS356	0	0.7	0	0
D224	DTZ5.1A	0	0	0	1.0
D225	1SS226	0	0	0	0

3) Connector

H201, H202, H203, H204

	Pin No.	RX Voltage	TX Voltage
H201	1	0	0
	2	4.8	2.8
H202	1	7.5	7.5
	2	8.6	0
H203	1	0.3	0.3
	2	8.9	8.9
	3	0	0
	4	0	0
	5	0	0
	6	0	0
	7	7.5	7.5
H204	1	8.9	8.9
	2	2.2	2.2
	3	0	0
	4	0	0
	5	4.1	4.1
	6	7.4	7.4
	7	0.2	0.2
	8	0	0

J203, J204, J207

	Pin No.	RX Voltage	TX Voltage
J203	1	0	-
	2	0	-
	3	0	-
	4	0	-
	5	0	-
	6	0	-
	7	6.0	-
	8	0	-
	9	8.9	0
	10	4.6	4.4
	11	1.5	0
J204	1	4.1	-
	2	0.2	-
	3	2.7	-
	4	0	-
	5	0	-
	6	0	-
	7	0	-
	8	0	-
	9	13.7	-
	10	0	-
	11	0	-
J207	+	13.7	13.7
	-	0	0

4) IC

IC201 TK10930VTL

Pin No.	RX Voltage
1	8.1
2	7.5
3	7.5
4	8.2
5	0
6	0
7	1.3
8	1.3
9	1.3
10	8.0
11	8.2
12	3.8
13	0.2
14	0.7
15	0
16	2.2
17	0
18	0
19	4.4
20	4.2
21	1.2
22	4.6
23	0
24	1.4

IC205 MB1504LPF-G-BND-TF

Pin No.	RX Voltage	TX Voltage
1	2.5	2.5
2	2.7	2.7
3	8.9	8.9
4	6.0	6.0
5	4.8	2.8
6	0	0
7	6.1	6.1
8	4.4	4.4
9	0	0
10	0	0
11	0.1	0.1
12	6.1	6.1
13	0	0
14	0	0
15	0	0
16	0	0

IC202 μ PC1241H

Pin No.	RX Voltage
1	0
2	1.9
3	1.2
4	0
5	0
6	6.9
7	12.7
8	13.7

IC203 TA7806F

Pin No.	Voltage
1	13.7
2	6.0
3	0

IC204 NJM7809A

Pin No.	Voltage
1	13.7
2	8.9
3	0

IC206 BU4094BF

Pin No.	RX Voltage	TX Voltage
1	L	L
2	L	L
3	L	L
4	L	L
5	L	H
6	H	H
7	L	L
8	0	0
9	L	L
10	L	L
11	L	L
12	H	L
13	L	L
14	H	H
15	H	H
16	H	H

IC207 BU4094BF

Pin No.	RX Voltage	TX Voltage
1	L	L
2	L	L
3	L	L
4	L	L
5	H	L
6	L	L
7	L	H
8	0	0
9	H	L
10	H	L
11	H	L
12	H	H
13	H	H
14	H	H
15	H	H
16	H	H

IC208 S-AV17

Pin No.	TX Voltage
1	-
2	13.7
3	6.4 (H) 5.5 (M) 4.5 (L)
4	0

PC BOARD VIEW

1) MIC Unit Side A

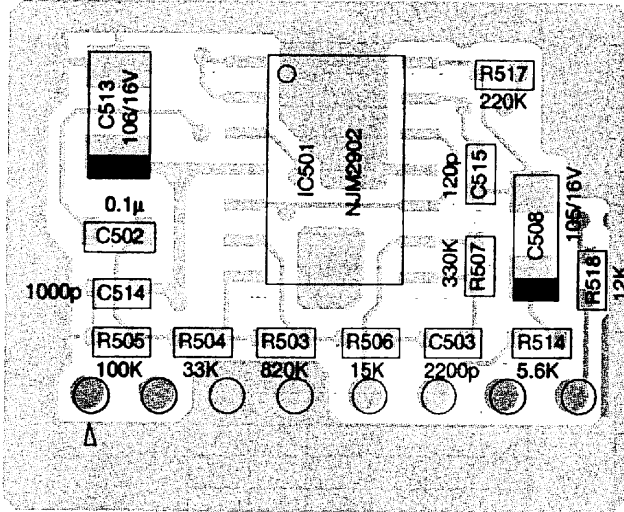

2) MIC Unit Side B

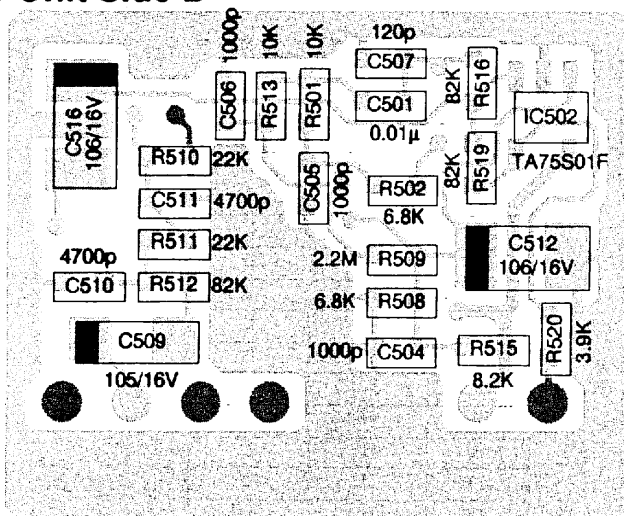

3) VCO Unit Side A

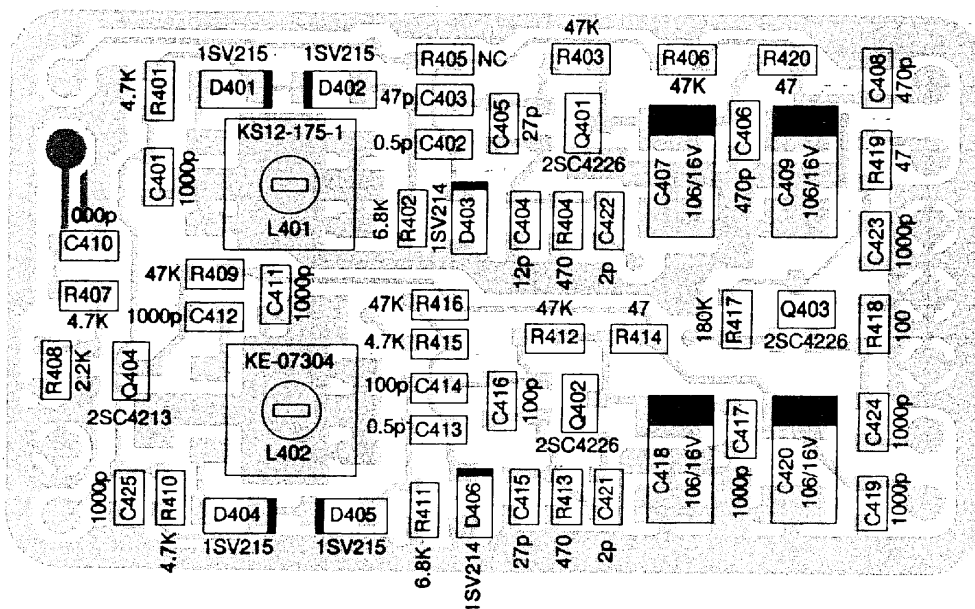

4) CPU Unit Side A

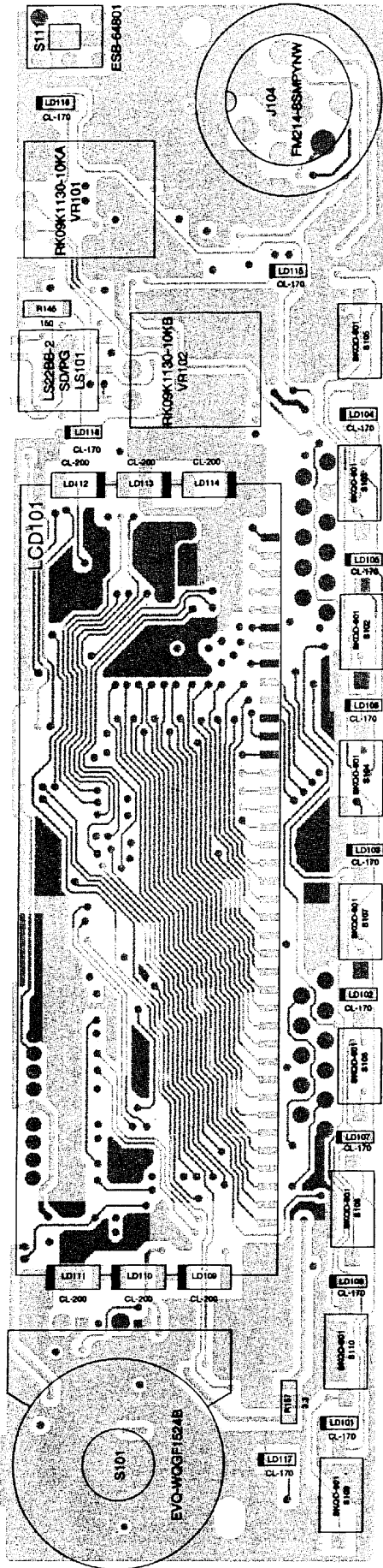

5) CPU Unit Side B

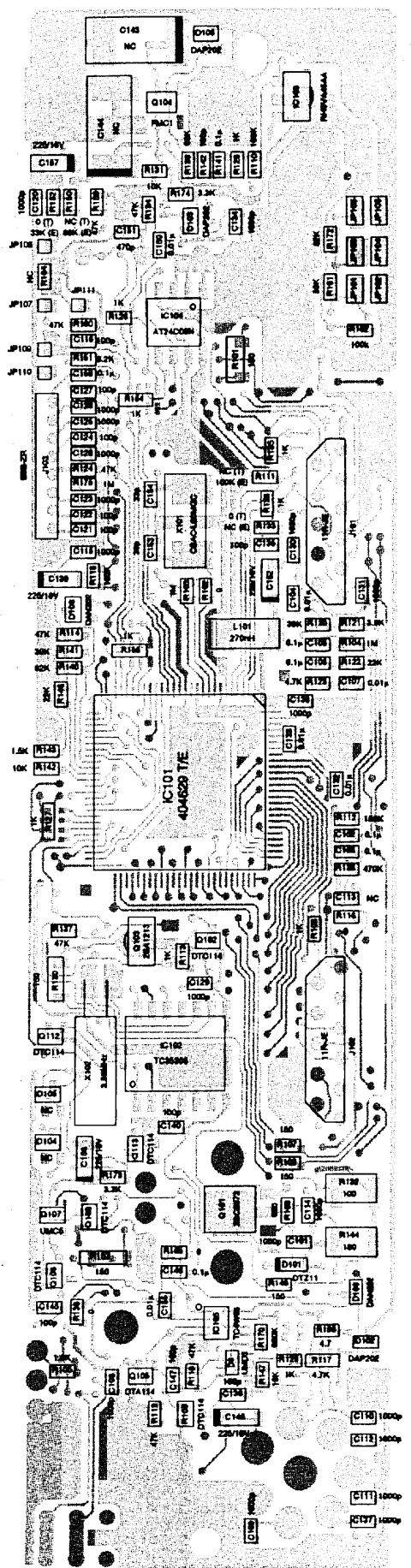

6) RF Unit Side A

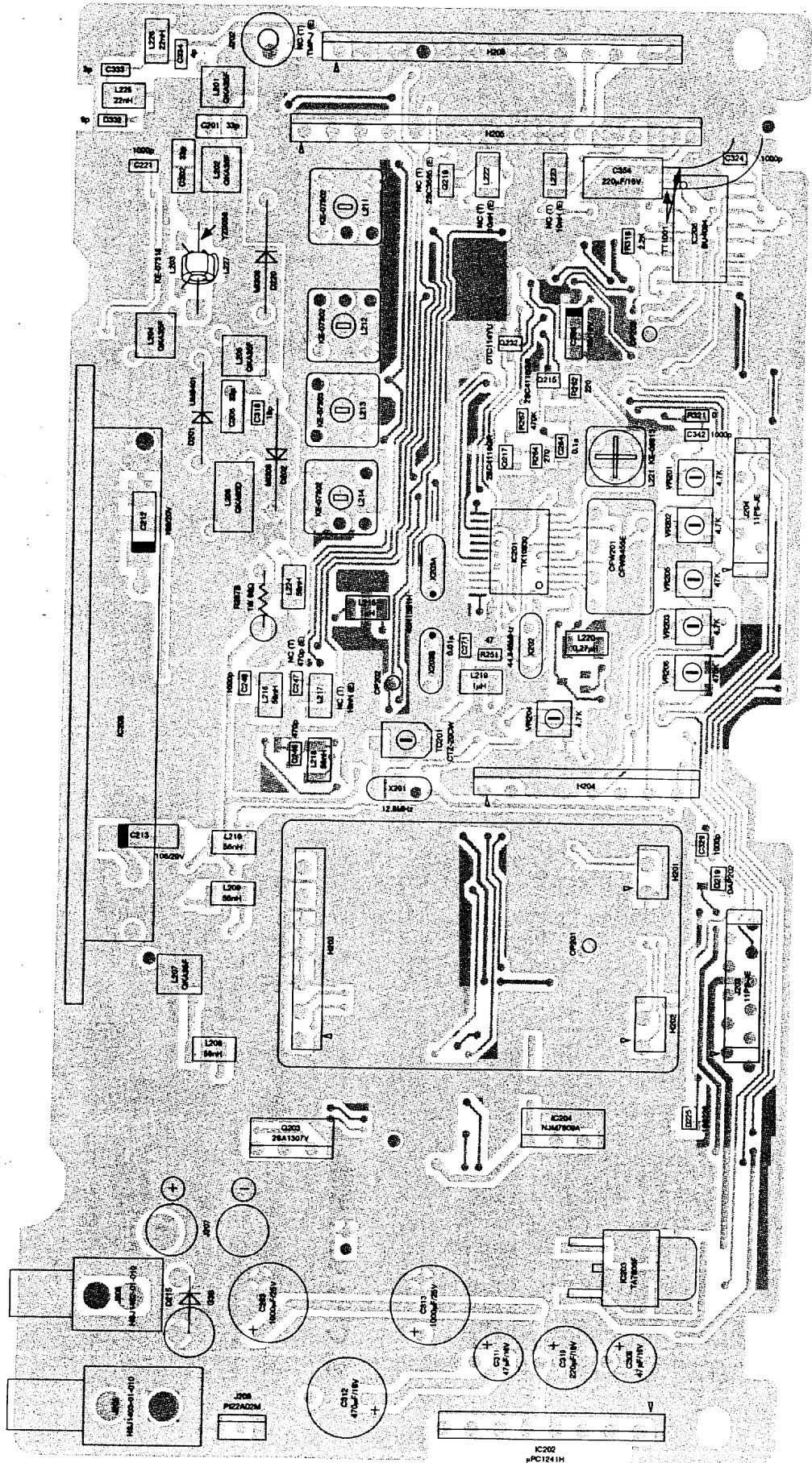

7) RF Unit Side B

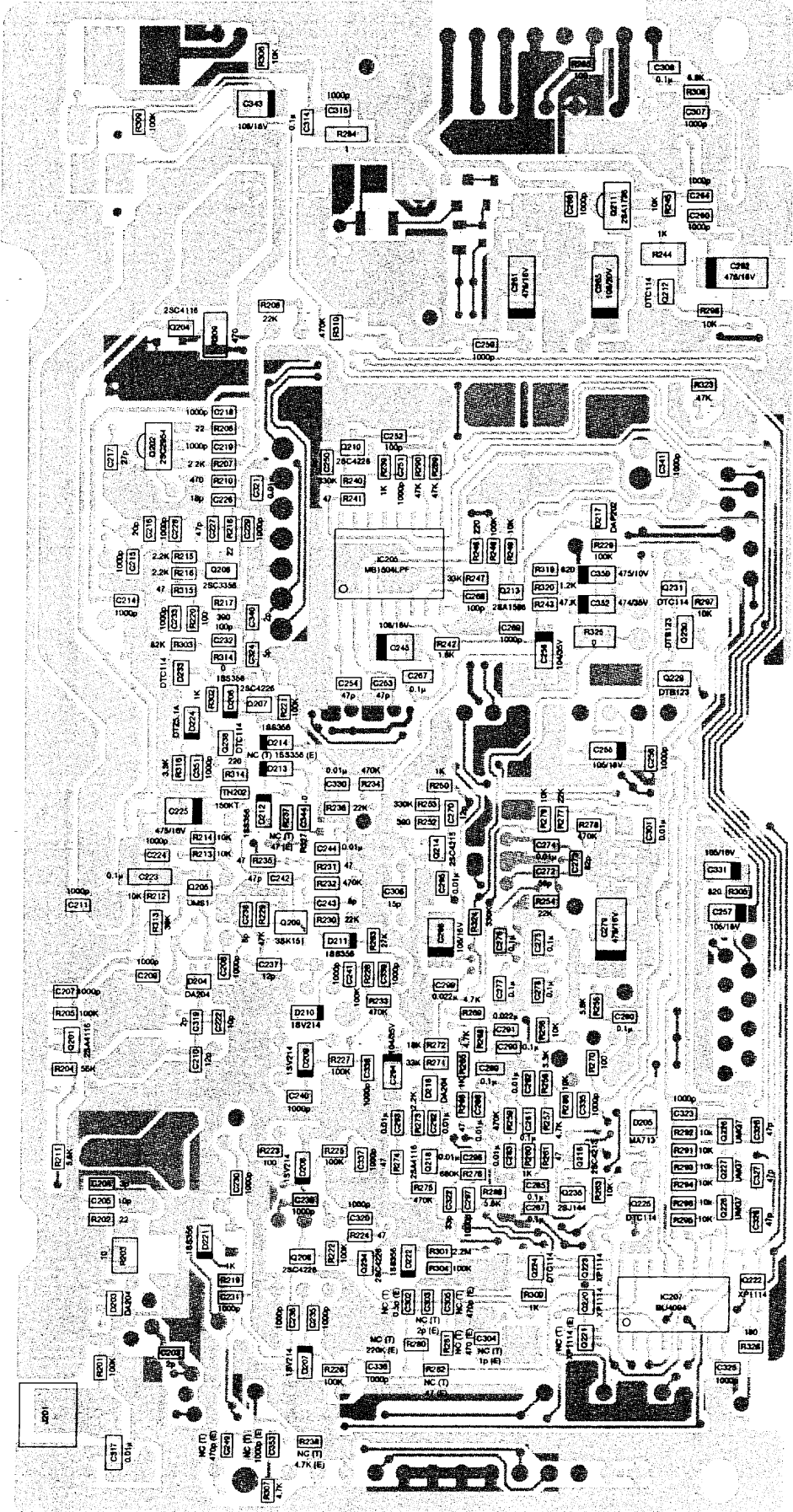

BLOCK DIAGRAM

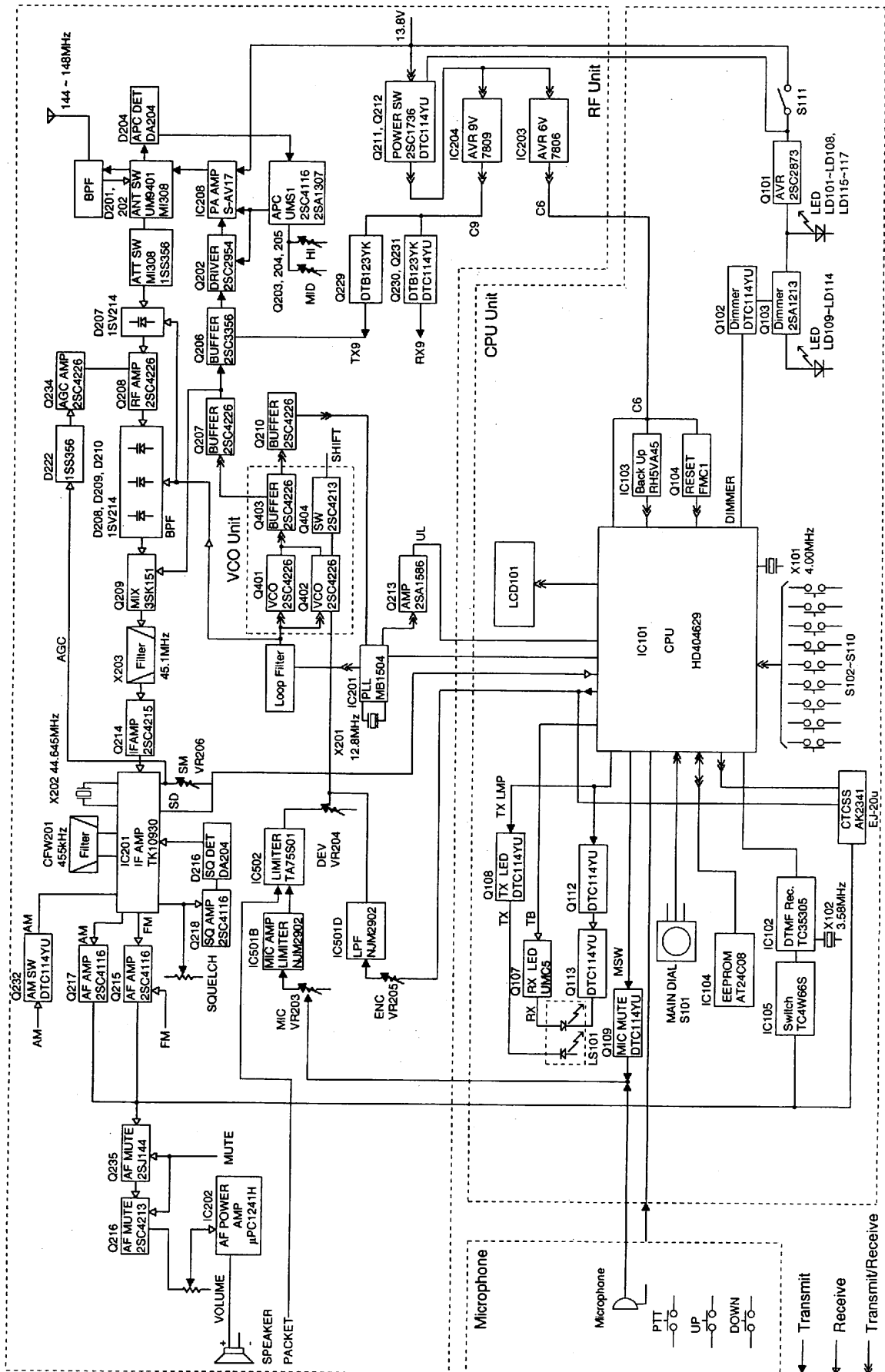

CIRCUIT DIAGRAM

1) MIC Unit

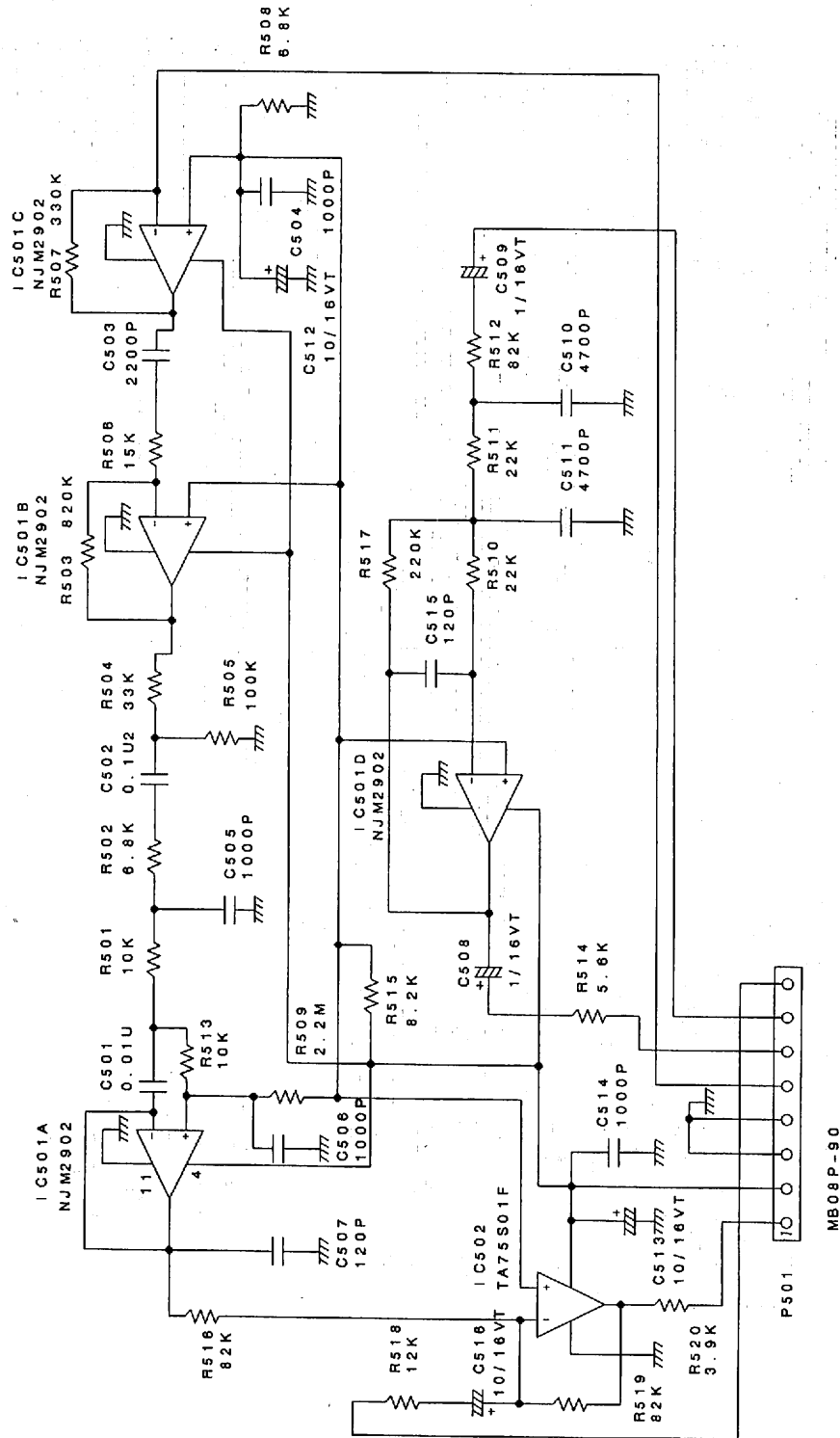

2) VCO Unit

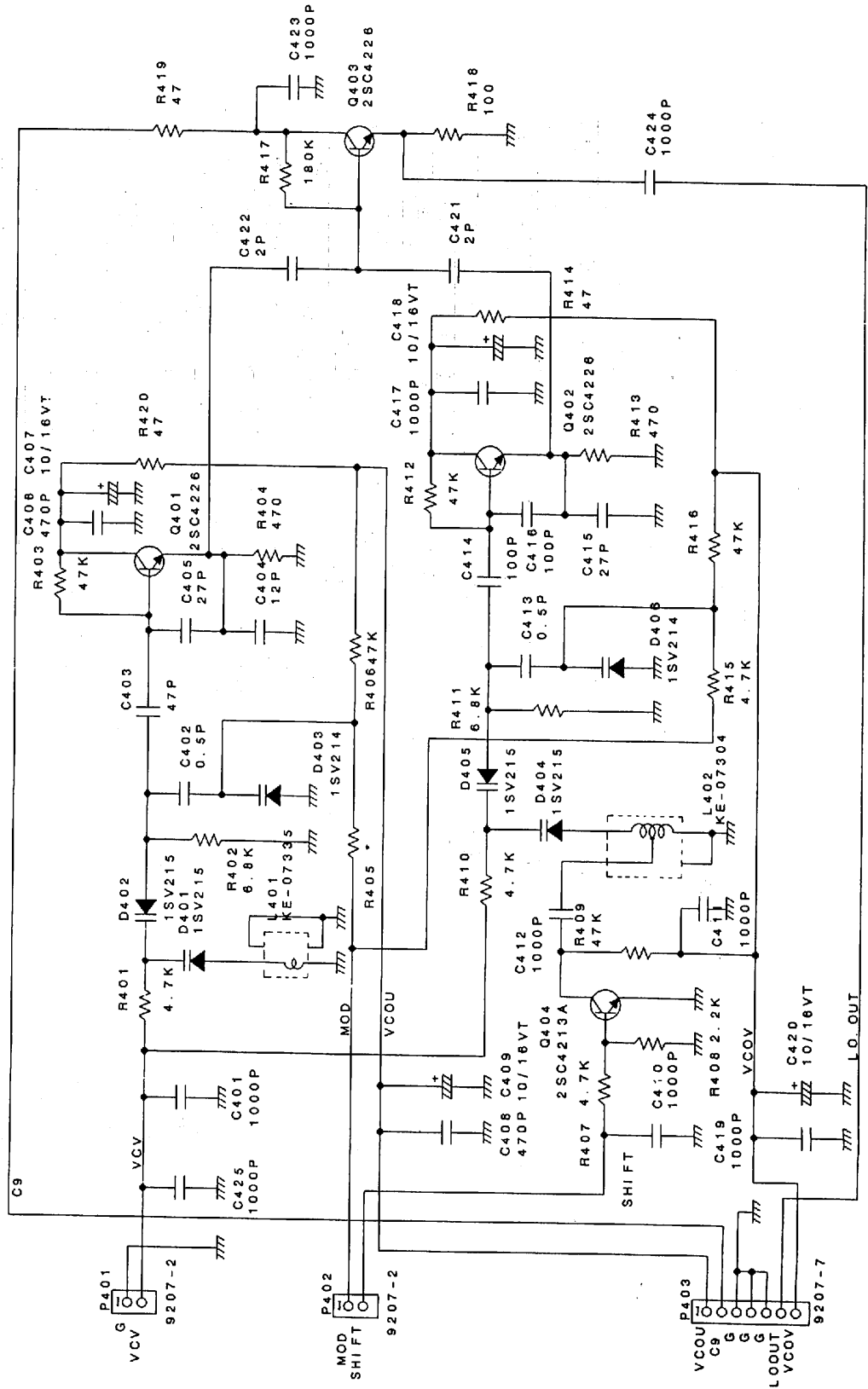

3) Main Unit

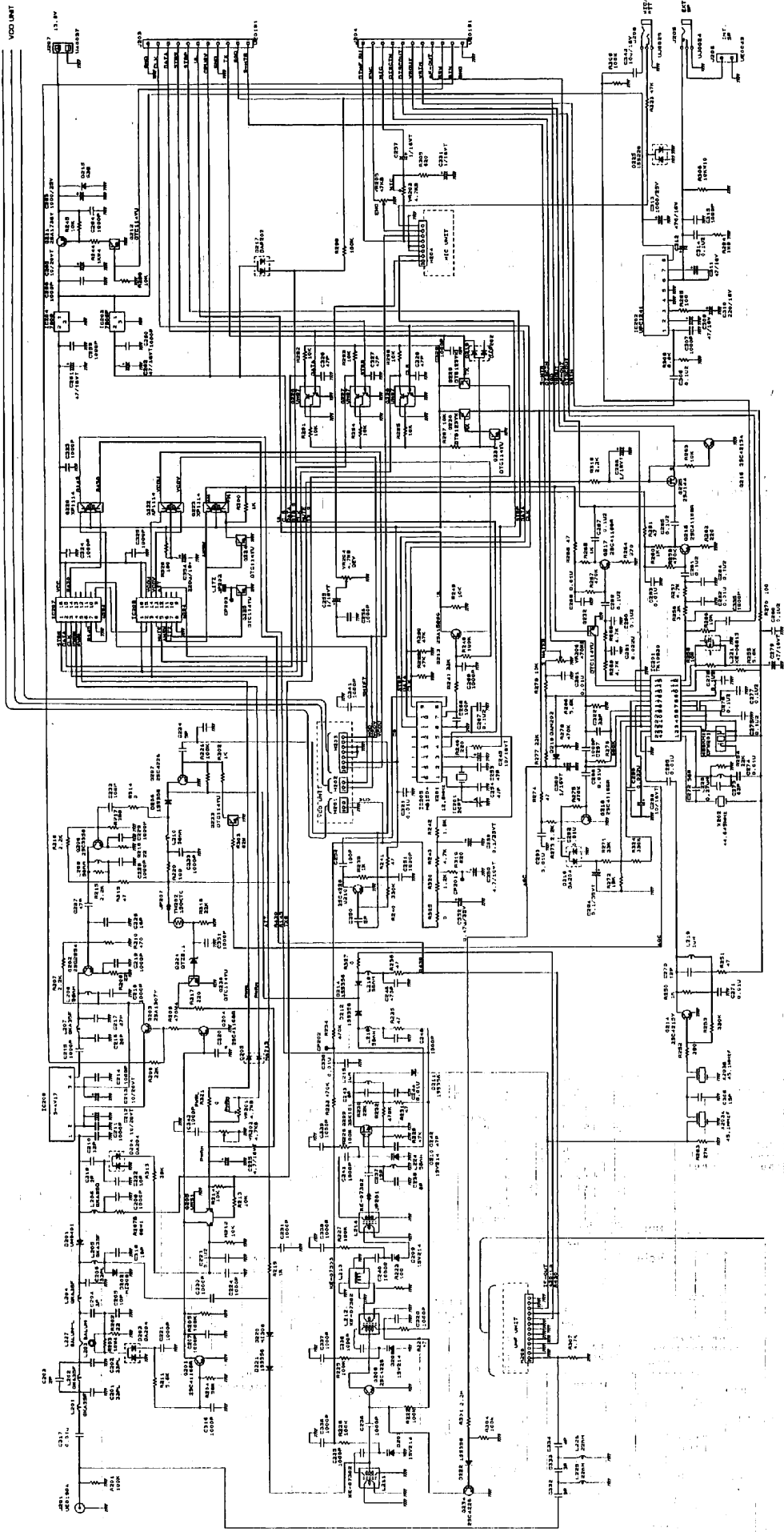

4) CPU Unit

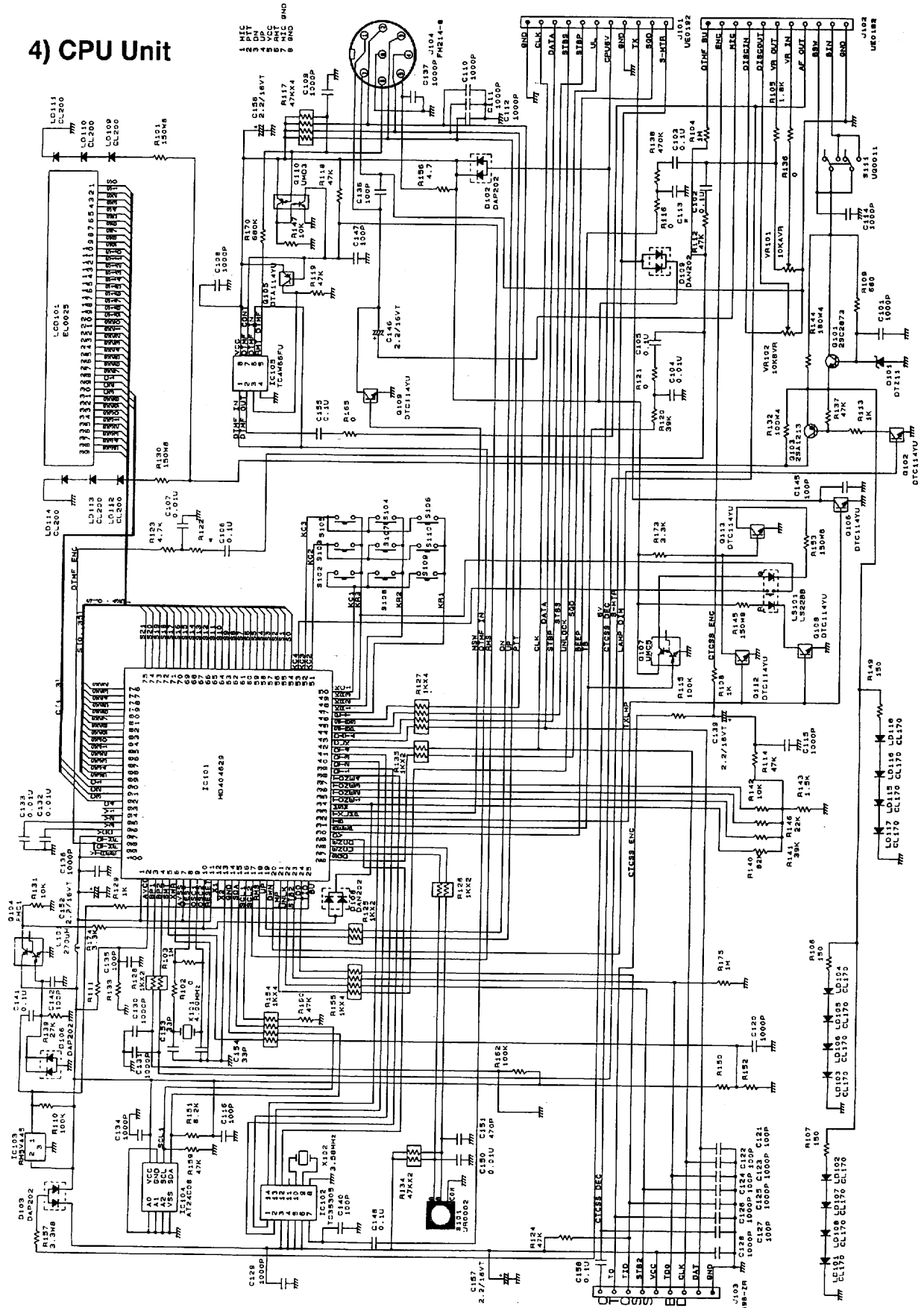

5) EJ20u Unit

